



ISO 9001
ISO 14001
PN-N-18001
OHSAS 18001



COMMON S.A.
ul. Aleksandrowska 67/93
91-205 Łódź
tel.: +48 42 253 66 00
tel.kom.: +48 601 255 580
fax: +48 42 253 66 99
e-mail: common@common.pl

TURBINE GAS METERS series CGT-02

OPERATION MANUAL

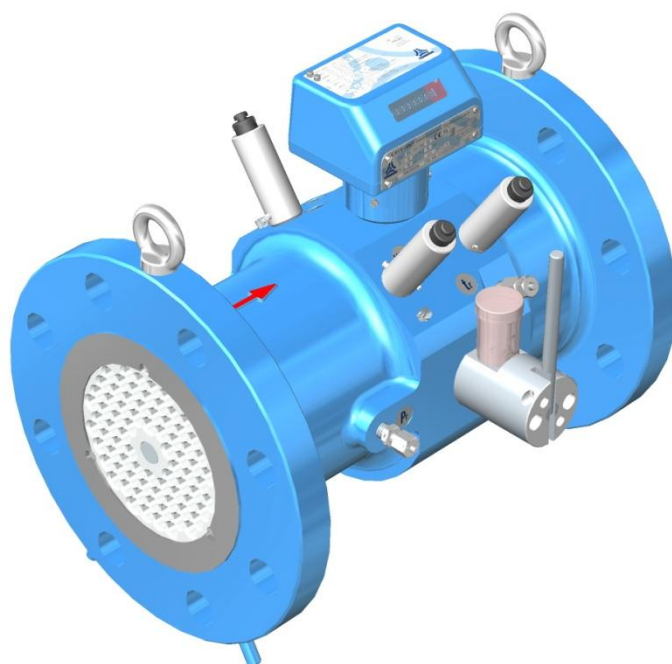

CGT – OM – 18

February 2018

**PLEASE READ THE OPERATION MANUAL BEFORE INSTALLING
AND OPERATING THE GAS METER**

Table of Contents

	<i>Page</i>
<i>I. INTENDED USE AND CONDITIONS OF USE</i>	<i>3</i>
<i>II. DESIGN AND FUNCTION</i>	<i>8</i>
<i>III. READOUT DEVICE AND MEASUREMENT OUTPUTS</i>	<i>10</i>
<i>IV. LABELING AND SEALING</i>	<i>18</i>
<i>V. PACKAGING, TRANSPORT AND STORAGE</i>	<i>23</i>
<i>VI. INSTALLATION AND OPERATION</i>	<i>28</i>
<i>VII. OPERATION MONITORING, MAINTENANCE, FAILURES, REPAIRS</i>	<i>36</i>
<i>VIII. ADDITIONAL EQUIPMENT</i>	<i>37</i>
<i>IX. LIST OF STANDARDS AND TECHNICAL SPECIFICATIONS</i>	<i>42</i>

I. INTENDED USE AND CONDITIONS OF USE

Intended use

CGT-02 turbine gas meters are electromechanical pressure devices designed to measure the volume of gas flowing through a system. In standard versions, the gas meters may be used at sites with probable occurrence of explosive atmospheres formed as mixtures of gases and air classified as explosion groups IIA and IIB. There are also special versions of meters for group IIC.

Table 1 lists the physical properties of the most common gases and gas mixtures that may be measured with CGT-02 gas meters. The gas meters are produced with the following connection types: PN10, PN16, PN20 (ANSI150), PN25, PN40, PN50 (ANSI300), PN63/PN64, PN100, PN110 (ANSI600).

The turbine gas meters can be used both indoors in stabilized temperature conditions and outdoors (open locations), however, in the latter case, it is recommended that the gas meter is shielded from direct exposure to atmospheric factors (metal containers, casings, roofs, shields etc.)

Conditions of use

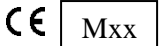

1. Directive 2014/32/UE (MID) compliance:

- Certificate	PL-MI002-1450CM0003, revision 6
- CE marking	 1450, Oil and Gas Institute
- working pressure range	$p \leq 11 \text{ MPa}$
- ambient temperature range	$-25^{\circ}\text{C} \leq t \leq +70^{\circ}\text{C}$
- gas temperature range	$-25^{\circ}\text{C} \leq t \leq +70^{\circ}\text{C}$
- storage temperature range	$-30^{\circ}\text{C} \leq t \leq +70^{\circ}\text{C}$
- mechanical environment class	M2
- electromagnetic environment class	E2
- metrological parameters	Table 2.
- metrological accuracy class	1.0
- operational position	H, HV, VU, VD (for $p \leq 0.4 \text{ MPa}$)
- operational position	H (for $0.4 \text{ MPa} < p \leq 11 \text{ MPa}$)
- installation conditions	inlet straight pipe with a length of 2 DN

2. IECEx Certificate of Conformity.

- certificate	IECEX KDB 15.0003
- marking standard version	Ex ia IIB T5 Gb
special purpose version	Ex ia IIC T5 Gb
- ambient temperature	$-25^{\circ}\text{C} \leq T_a \leq +70^{\circ}\text{C}$

3. Directive 2014/34/UE (ATEX) compliance:

- certificate	KDB 04ATEX036, annex 1, 2, 3 and 4
- CE marking	 1453, Central Mining Institute, Experimental Mine "Barbara"
- operation conditions : standard version	 II 2G Ex ia IIB T5 Gb
special purpose version	 II 2G Ex ia IIC T5 Gb
- meter case index of protection	IP66/IP67
- ambient temperature range	$-25^{\circ}\text{C} \leq T_a \leq +70^{\circ}\text{C}$

4. Directive 97/23/WE or 2014/68/UE (PED) compliance:

- certificate 10196/JN/2007/C6/001/04 or 59363/JN/001/04
- CE marking **CE** 1433, Office of Technical Inspection
- Maximum calculated pressure for gas meter bodies:

connection PN10	PS = 1.0 MPa
connection PN16	PS = 1.6 MPa
connection PN20	PS = 2 MPa
connection PN25	PS = 2.5 MPa
connection PN40	PS = 4 MPa
connection PN50	PS = 5 MPa
connection PN63	PS = 6.3 MPa
connection PN100	PS = 10 MPa
connection PN110	PS = 11 MPa
- ambient temperature range $-25^{\circ}\text{C} \leq \text{TS} \leq +70^{\circ}\text{C}$

5. Directive 2014/30/UE (EMC) compliance:

Requirements met by the use of LF and HF pulse emitters (NAMUR) compliant with the following harmonized standards: EN 60947-5-2:2007, EN 60947-5-6:2000).

Table 1. Physical properties of the most common gases and gas mixtures that may be measured with CGT-02 gas meters. Densities are specified under pressure of 101.325 kPa at 20°C

Gas or gas mixture	Chemical symbol (formula)	Density ρ [kg/m ³]	Density relative to air	Gas meter version
argon	Ar	1.66	1.38	standard IIB
nitrogen	N ₂	1.16	0.97	standard IIB
butane	C ₄ H ₁₀	2.53	2.1	standard IIB
carbon dioxide	CO ₂	1.84	1.53	standard IIB
ethane	C ₂ H ₆	1.27	1.06	standard IIB
ethylene	C ₂ H ₄	1.17	0.98	standard IIB
natural gas	≈CH ₄	ca. 0.75	ca. 0.63	standard IIB
helium	He	0.17	0.14	standard IIB
methane	CH ₄	0.67	0.55	standard IIB
propane	C ₃ H ₈	1.87	1.56	standard IIB
carbon monoxide	CO	1.16	0.97	standard IIB
acetylene	C ₂ H ₂	1.09	0.91	special IIC
hydrogen	H ₂	0.084	0.07	special IIC
air	–	1.20	1	standard IIB

The basic metrological parameters of CGT-02 turbine gas meters are listed in Table 2. The table should not be taken as current sales offer; relevant information may be obtained at the Marketing Department.

The gas meter causes a gas pressure drop in the system. The value of the pressure drop of CGT-02 gas meters at Qmax maximum flow (**specified for air at atmospheric conditions, i.e. at density $\rho_0 = 1,2 \text{ kg/m}^3$**) is specified in Table 2.

In actual conditions, pressure loss Δp_r [Pa] is calculated from the formula:

$$\Delta p_r = \rho_w \frac{p_a + p}{p_a} \cdot W_{pd} \cdot \Delta p$$

where: $\rho_w = \rho / \rho_0$ – relative gas density (related to air) according to Table 1,

p_a – atmospheric pressure ($p_a \cong 101$ [kPa]),

p – gauge pressure at meter's inlet [kPa],

W_{pd} – pressure drop coefficient according to Figure 1.

Δp – pressure drop at Qmax according to Table 2 [Pa].

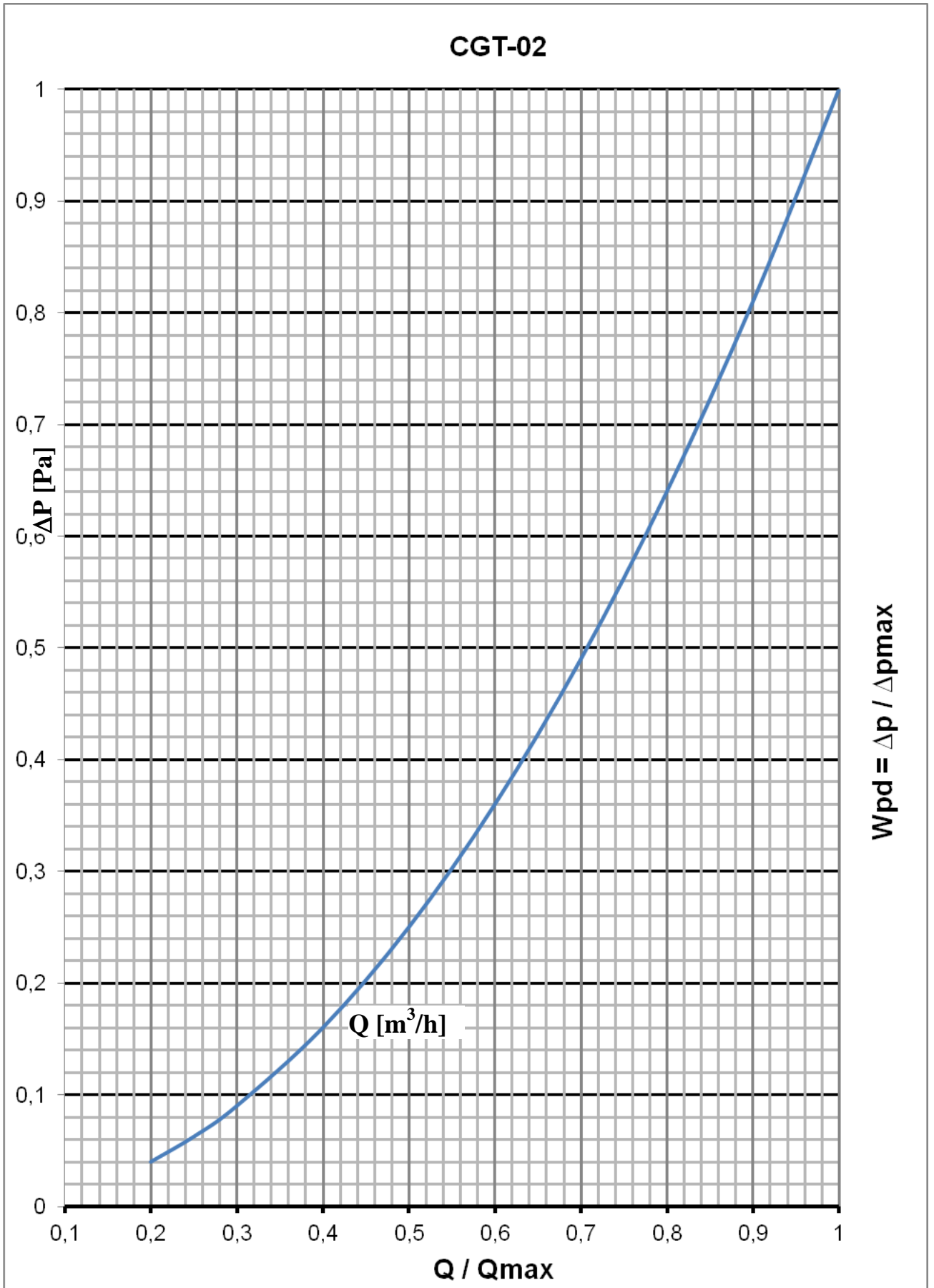

Fig. 1. **Wpd** pressure drop coefficient as a function of relative flux Q/Q_{max}

Table 2. Basic metrological parameters of CGT-02 meters

DN nominal diameter	G gas meter size	Q _{max} maximum flow	Q _{min} minimum flow at rangeability:				LF emitter constant	HF1, HF2 emitter constant (approximate)	HF3 ÷ HF6 emitter constant (approximate)	Δp ⁽³⁾ for Q _{max}
			1:20 ⁽¹⁾	1:20	1:30	1:50 ⁽²⁾				
-	-	m ³ /h	[m ³ /h]	[m ³ /h]	[m ³ /h]	[m ³ /h]	[pulses / m ³]	[pulses / m ³]	[pulses / m ³]	[Pa]
DN 50	G 65	100	5	5	-	-	10	2610	94829	760
DN 80	G 100	160	8	8	-	-	1	742	26974	260
	G 160	250	13	13	8	-	1	742	26974	620
	G 250	400	20	20	13	8	1	470	17059	1500
DN 100	G 160	250	13	13	8	-	1	692	16782	260
	G 250	400	20	20	13	8	1	692	16782	670
	G 400	650	32	32	20	13	1	401	9719	1580
DN 150	G 400	650	32	32	20	13	1	227	6873	280
	G 650	1000	50	50	32	20	1	227	6873	720
	G1000	1600	80	80	50	32	0,1	129	3910	1600
DN 200	G 650	1000	-	50	32	20	1	114	3113	260
	G 1000	1600	-	80	50	32	0,1	116	3167	760
	G 1600	2500	-	130	80	50	0,1	67	2025	1700
DN 250	G 1000	1600	-	80	50	32	0,1	58	2111	310
	G 1600	2500	-	130	80	50	0,1	58	2111	760
	G 2500	4000	-	200	130	80	0,1	34	1223	1550
DN 300	G 1600	2500	-	130	80	50	0,1	32	1181	260
	G 2500	4000	-	200	130	80	0,1	32	1181	650
	G 4000	6500	-	320	200	130	0,1	19	680	1600
DN 400	G 2500	4000	-	200	130	80	0,1	13	444	170
	G 4000	6500	-	320	200	130	0,1	13	444	440
	G 6500	10000	-	500	320	200	0,1	7,0	285	900

(1) – refers to gas meters operating in HV positions, equipped with sealed bearings or a check valve dedicated for periodic lubricant application (without piston pump and oil container)

(2) – refers to gas meters for working pressures (p) 2 ÷ 11 MPa.

(3) – for particular gas meters the measured pressure drop value can be different by ± 5 % from values specified in Table2.

NOTE: For gas meters equipped with all options (2 HF sensors on the turbine wheel & 2 HF sensors on the reference wheel & 2 thermowells) the Δp pressure drop can be increased by 20%.

II. DESIGN AND FUNCTION

Operation of the turbine gas meter is based on the principle of proportionality of the speed of rotation of a turbine rotor to the linear velocity or the volumetric flow of gas. The gas flowing into the gas meter (fig. 2) is directed via an inlet straightener into the measurement assembly and triggers the rotation of the rotor. The rotational motion of rotor is transmitted to the counter by means of cog gears and magnetic coupling. The counter mechanism totals up the volume flowing through the device, and an 8-digit counter indicates the total volume. Each gas meter of the CGT-02 series is verified in the range of Q_{\min} to Q_{\max} (Table 2), and in that range the accuracy of the meter is verified.

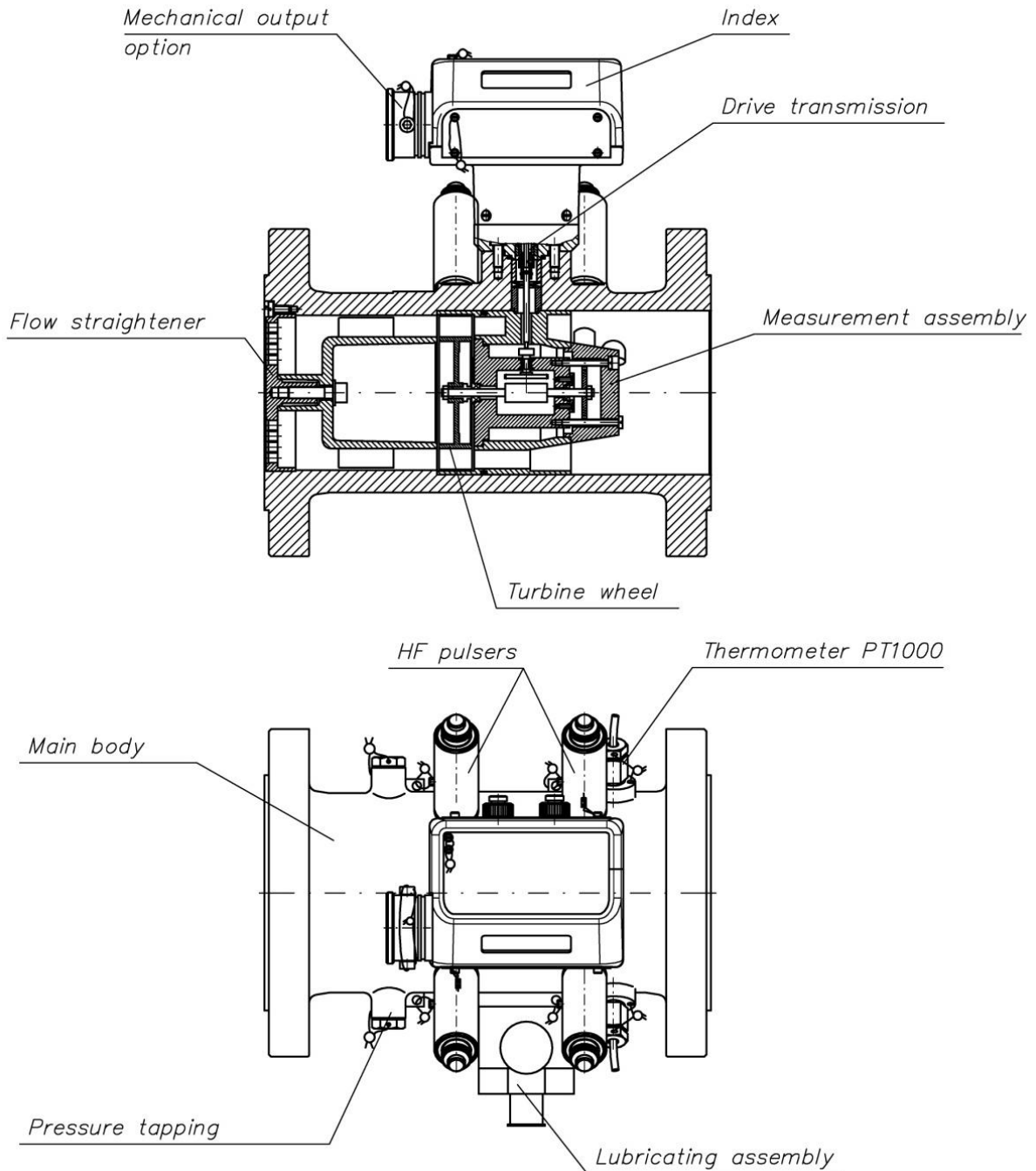

Fig. 2 Cross-section of the turbine gas meter CGT-02

The turbine gas meter CGT-02 (Fig. 2) is built of the following units:

Main body. The main body carries all loads coming from both the gas pressure and the installation stresses in the pipeline. Bodies of the gas meters with nominal diameters of DN50 up to DN200 and PN16 or PN20 pressure flange ratings may be manufactured in two versions – either machined steel forgings or ductile iron castings. Bodies of PN25, PN40, PN50, PN63, PN100 and PN110 ratings are available only as steel versions. Bodies of nominal diameters DN250 and larger are always made of welded steel. Each body is equipped with two connection flanges with type “B” faces and connection dimensions compliant with the EN 1092-1:2007+A1:2013 and the ISO 7005-1:1992 standards. The flange dimensions, as well as overall dimensions and estimated weights of the gas meters in standard versions are listed in Tables 3a and 3b and indicated in Figure 18. On special orders, the body may be delivered with different types of flange facings compliant with European, ANSI or GOST standards. Gas meters bodies are fitted with connectors for high frequency signal emitters, sockets for pressure gauges and sockets for thermowells (see section III).

Measurement turbine assembly. The measurement turbine assembly consists of the turbine, the gear system and the inlet straightener. The turbine rotor is placed along the gas meter body axis and seated on two high precision ball bearings. The flow straightener placed in front of the turbine makes the gas flow symmetrical and directs it onto the turbine blades. The gear system (consisting of a worm gear and a spur gears) reduces and transfers the rotational speed and transmits the drive onto the magnetic coupling.

Drive transmission assembly. The drive transmission assembly consists of a magnetic coupling with gas-tight partition. The driving part of the coupling is located inside the partitioned chamber, while the driven part is located outside the partitioned chamber. The coupling transmits the drive from the pressure zone to the counter assembly, located outside the gas flow area. The driven part of the coupling may be equipped with a reference wheel acting as an inducer for the high frequency emitter.

The index assembly. The index assembly reduces the rotational speed further (by means of a worm gear and spur gears) to drive the mechanical counter and the parts that induce the low frequency electric signal emitters. The assembly is also fitted with sockets (electrical outputs) for transmitting the low and high frequency electric signals outside the gas meter. The gas meter counter can be optionally equipped with a mechanical output. Optionally the CWSL Encoder can be connected to the optional mechanical output. There are 3 versions of (optional) Encoders available: CWSL-N, CWSL-A, CWSL-M. Data sent from CWSL-N are equal to data on the index.

Lubrication system. The lubrication system is used to lubricate the turbine rotor bearings. The other mechanisms of CGT-02 gas meters are not subject to external lubrication and make use of bearings equipped with grease reserves. The greasing of the rotor bearings may be executed by means of a manual piston pump with integrated oil container or via a lubrication kit.

The CGT-02 series gas meters are offered in the following versions:

- maintenance-free (without external lubrication, with spare quantity of grease in bearings);
- with special valve for periodic external lubrication (with a lubrication kit);
- with piston pump for external lubrication.

The CGT-02 series gas meters can be equipped with piston pumps of the following four types:

- | | | |
|-----------------------|---------------------------------------|---------------------------|
| P1 – with pushbutton, | $p_{\max} \leq 2$ [MPa], | DN50, DN80, DN100, DN150, |
| D1 – with lever, | 2 [MPa] < $p_{\max} \leq 11$ [MPa], | DN50, DN80, DN100, DN150, |

D2 – with lever, $p_{\max} \leq 6.3$ [MPa], DN200, DN250, DN300, DN400,
 D3 – with lever, 6.3 [MPa] < $p_{\max} \leq 11$ [MPa], DN200, DN250, DN300, DN400.

Typical DN50 gas meters are not adapted for external lubrication. These meters can be optionally equipped with piston pump or lubrication valve.

A sticker is attached to the oil container cover, providing information about the type of the pump used and the type of oil which should be used. Information about the type of oil is also provided on the lubrication valve cover.

III. READOUT DEVICE AND MEASUREMENT OUTPUTS

The gas meter CGT-02 is equipped with a readout device in the form of a mechanical counter with electric signal outputs. The body of the gas meter is equipped with sockets for implementation of external HF emitters and sockets for the (optional) measurement of pressure and temperature. Such measurements enable monitoring the gas meter operation and connecting to the external equipment. Fig. 3 shows the location of the measurement outputs of the gas meter.

The mechanical counter is located inside the index head assembly and visible through a polycarbonate inspection window. The counter allows direct readout of the actual volume of gas that has flown through the gas meter under particular pressure and temperature conditions. The index assembly may be rotated around its axis in a range of ca. 350° , allowing for convenient readout of the counter from virtually all directions.

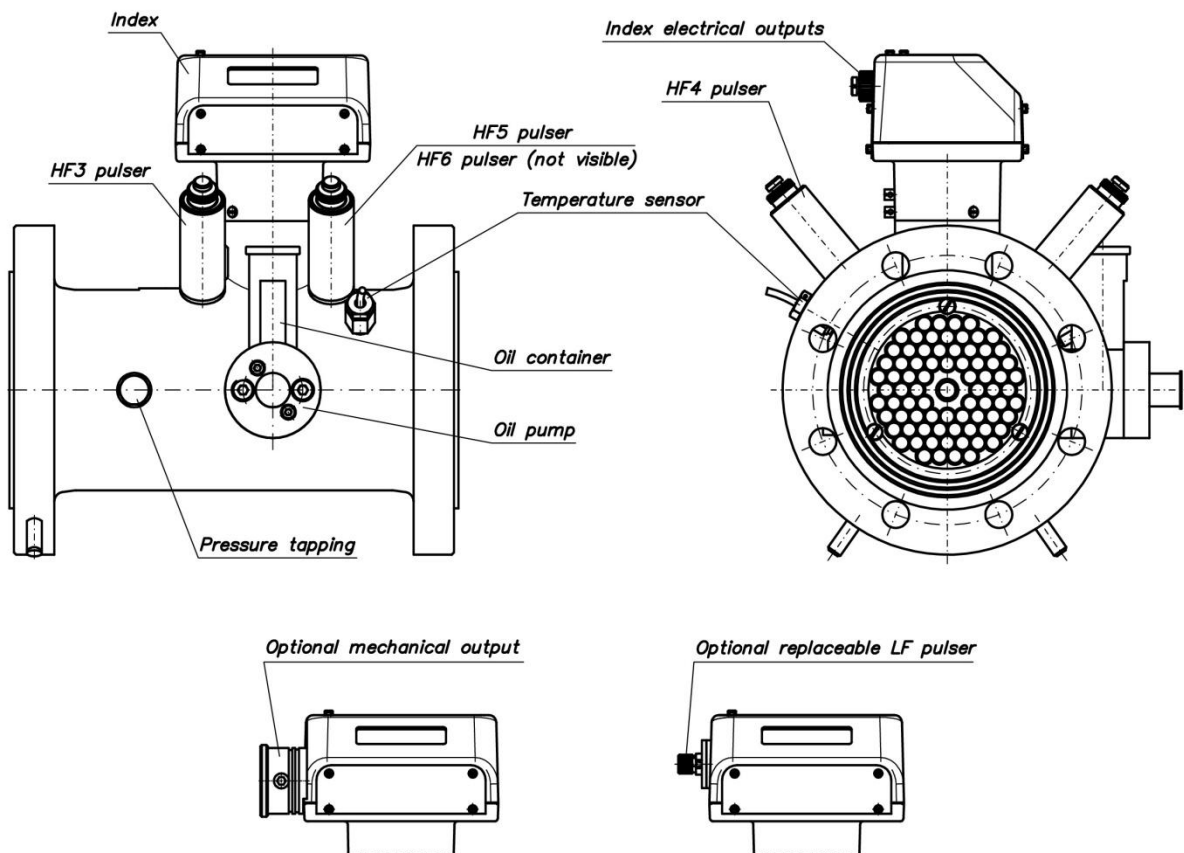

Fig. 3. Location of measurement outputs of CGT-02 gas meters.

Mechanical counter output. The gas meter may be optionally equipped with a mechanical output. A flattened tip of the counter shaft is located on the left side of the index head and covered by a protective cap. The mechanical output may be used to drive external devices. The rotational speed of the shaft is identical to the speed of the fastest counter drum. The shaft rotates counter clockwise which is marked on the name plate located on the housing of mechanical output (Fig. 11). There are also 2 other values specified on this name plate: $M_{max} = 0,25$ [Nmm] maximum permissible torque load on the shaft of the mechanical output, and $1 \text{ tr} = \dots\dots$ [m^3] value of the constant corresponding to one rotation of the shaft.

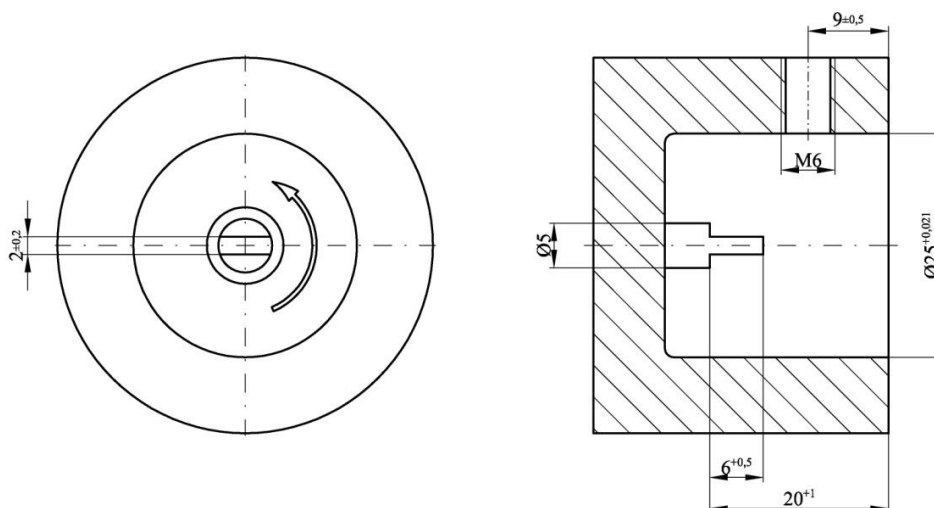

Fig. 4. Mechanical output dimensions

Electrical counter outputs. There are two possible types of electric signal outputs: low frequency (LF) outputs and high frequency (HF) outputs. The index head can be equipped with one or two 6-pins sockets. Up to three electric pulse emitters can be connected to each of the sockets. The pulse emitters are:

- one or two inductive high frequency emitters HF,
- one or two inductive low frequency emitters LFI,
- one or two low frequency reed contact emitters LFK,
- one or two low frequency emitters LFW equipped with Wiegand sensor
- one control circuit utilising normally closed reed relay switch AFK.

The reed relay emitters LFK and LFW are designed to work with a battery-powered or grid/battery-powered data logger and volume converter located in the vicinity of the gas meter (up to ca. 2 m). The induction emitters, both of the LFI and the HF type, may emit electric current signals over significantly longer distances (up to ca. 200 m, depending on conditions). Due to high power consumption, they are designed to work only with grid-powered volume converters. Gas volumes corresponding to individual pulses of the LF emitter are presented in Table 2.

The number of HF pulses per one cubic meter of gas is determined individually for each gas meter and listed on the type plate.





All emitters located in the gas meter index head are connected to Tuchel C091 31N006 100 2 or Lumberg Connect 0304 06 sockets located in the back wall of the index. Cords connected to sockets should be equipped with Tuchel C091 31H006 100 2 or Lumberg 0332 06 plugs. Tuchel connections in CGT-02 gas meters are of the IP67 protection class. Table 3 presents possible connections of emitters to individual electric signal output sockets.

Table 3. Possible connections of gas meter emitters to index output sockets

	Pin	Polarity	LFK 1 or LFW 1		LFK 2 or LFW 2		AFK		(*) LFI 1		(*) LFI 2		HF 1		HF 2		
			S														
Socket 1	1	-	S						O								
	4	+		S						O							
	2	-			O		P		P		O				O		
	5	+				O		P		P		O				O	
	3	-						O						P			
	6	+							O						P		
Socket 2	1	-			P				O								
	4	+				P				O							
	2	-			O		O		O		P				O		
	5	+				O		O		O		P				O	
	3	-											O		P		
	6	+												O		P	
<p>S – standard connections, P – preferred connections, O – optional connections (*) – not available with replaceable LF sensors The view and numbering of the pins Sockets 1 and 2 is shown in Figure 9a (9b).</p>																	
Standard versions of the CGT-02 gas meter features only one low frequency reed contact emitter LFK 1																	
ATTENTION! In the case where two sockets in the index head are used as an output for the sensor's circuits, the cables connected to those sockets should be marked with tags indicating the socket number to which the specified cable should be connected.																	

One of the inductive emitters HF3 to HF6 installed in the gas meter body may act as a control element in the CGT-02 meter. The constants for emitters HF3-HF6 are listed on the type plate.

In line with the conditions of use, the CGT-02 gas meters should be equipped with emitters allowing for at least  II 2G Ex ib IIC T5 Gb protection. This condition is satisfied for instance by the following emitters used in the index:

- HF type Bi1-EG05-Y1⁽¹⁾ by Hans Turck GmbH
Certificate No. IECEx KEM 06.0036X marking Ex ia IIC T4... T6
Certificate No. KEMA 02ATEX1090X marking  II 1G Ex ia IIC T4...T6 or  II 2G Ex ia IIC T4...T6
- LFI type Si5-K09-Y1⁽¹⁾ by Hans Turck GmbH
Certificate No. IECEx KEM 06.0036X marking Ex ia IIC T4... T6
Certificate No. KEMA 02ATEX1090X marking  II 1G Ex ia IIC T4...T6 or  II 2G Ex ia IIC T4...T6
- LFK type CLFK-03 by Common S.A.
- LFW type CLFW-01 by Common S.A.
- LFW type CLFW-02 by Common S.A.

(1) – required linear characteristics of the emitter power circuit.

Acceptable intrinsic safety parameters

Bi1-EG05-Y1	Si5-K09-Y1	CLFK-03	CLFW-01 CLFW-02
$U_i = 20 \text{ V DC}$	$U_i = 20 \text{ V DC}$	$U_i = 15.5 \text{ V DC}$	$U_i = 30 \text{ V DC}$
$I_i = 60 \text{ mA}$	$I_i = 60 \text{ mA}$	$I_i = 52 \text{ mA}$	$I_i = 52 \text{ mA}$
$P_i = 200 \text{ mW}$	$P_i = 130 \text{ mW}$	$P_i = 169 \text{ mW}$	$P_i = 0.6 \text{ W}$
$L_i = 150 \mu\text{H}$	$L_i = 350 \mu\text{H}$	$L_i \approx 0$	$L_i \approx 0$
$C_i = 150 \text{ nF}$	$C_i = 250 \text{ nF}$	$C_i \approx 0$	$C_i \approx 0$
ATTENTION!			
The total voltage of separate galvanic intrinsically safe circuits connected to one connector must comply with: $U_{i1} + U_{i2} \leq 30 \text{ V}$			

Intrinsic safety parameters of the emitters installed in the gas meter are listed on the type plate.

The security level is also met by the following interchangeable transmitters:

- LFK type CLFK-04 manufactured by Common S.A.
- LFW type CLFW-04 manufactured by Common S.A.

Acceptable intrinsic safety parameters

CLFK-04	CLFW-04
$U_i = 15.5 \text{ V DC}$	$U_i = 30 \text{ V DC}$
$I_i = 52 \text{ mA}$	$I_i = 52 \text{ mA}$
$P_i = 169 \text{ mW}$	$P_i = 0.6 \text{ W}$
$L_i \approx 0$	$L_i \approx 0$
$C_i \approx 0$	$C_i \approx 0$

Electrical outputs for HF emitter signals in the gas meter body.

The high frequency pulse emitters may be placed in the main body of the gas meter over the turbine rotor or over the reference wheel (option), which features the number of cogs equal to the number of turbine blades. In such case, the magnetic field of the HF emitter is modulated by the turbine rotor or the reference wheel giving the same pulse rate. The HF emitters can be installed as shown in Fig. 3. The sockets feature a M16 x 1.5 thread (Fig. 5).

Installation of the HF emitter in the gas meter body requires high precision and the use of electronic control equipment and such must be performed only by a representative of the manufacturer or a company authorized by the manufacturer.

Maximum of four near field inductive high frequency emitters (HF) may be installed in the gas meter:

- one or two HF emitters over the turbine rotor,
- one or two HF emitters over the optional reference wheel.

The emitters should allow for at least Ex ib IIC T5 Gb protection. These conditions are satisfied, for example, by the following emitters:

- **CHFI-01** by Common S.A., equipped with Bi1-EG05-Y1⁽¹⁾ sensors (Hans Turck GmbH: Certificate No.: IECEx KEM 06.0036X, marking Ex ia IIC T4...T6 and Certificate No.: KEMA 02ATEX1090X marking $\text{Ex II 1G Ex ia IIC T4...T6}$ or $\text{Ex II 2G Ex ia IIC T4...T6}$)
- **CHFI-03** by Common S.A., equipped with Bi3-EG12-RY1/S1000⁽¹⁾ sensors (Hans Turck GmbH, Certificate No.: KEMA 02ATEX1152X marking $\text{Ex II 1G Ex ia IIC T4...T6}$ or $\text{Ex II 2G Ex ia IIC T4...T6}$)

(1) – required linear characteristics of the emitter power circuit.

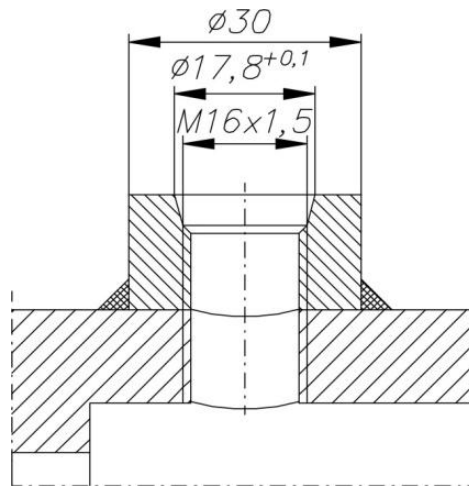

Fig. 5. Dimensions of the sockets for the HF pulse emitters.

Acceptable intrinsic safety parameters:

CHFI-01	CHFI-03
$U_i = 20 \text{ V DC}$	$U_i = 20 \text{ V DC}$
$I_i = 60 \text{ mA}$	$I_i = 60 \text{ mA}$
$P_i = 200 \text{ mW}$	$P_i = 200 \text{ mW}$
$L_i = 150 \text{ }\mu\text{H}$	$L_i = 350 \text{ }\mu\text{H}$
$C_i = 150 \text{ nF}$	$C_i = 180 \text{ nF}$

Intrinsic safety parameters are listed in the type plate located at the emitter casing (Fig. 10).

The emitters are equipped with 4-pin Tuchel C091 31W004 100 2 connectors. They should be connected to cords with Tuchel C091 31D004 100 2 slots. The emitter is connected to pins 3 and 4. Figure 6 presents a diagram of the connection of the emitter to the measurement circuit.

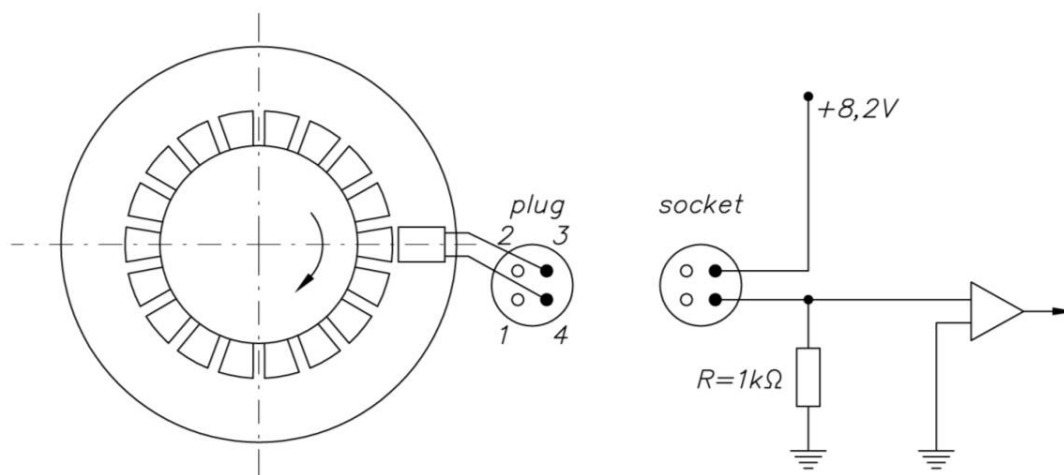

Fig. 6. Diagram of the HF emitter connection

The number of HF pulses per one square meter of gas is determined individually for each gas meter and listed on the electrical outlets type plate. (Figs. 9 and 10), placed at the top of the index head.

NOTE!

Intrinsic safety parameters are electrical parameters designated during analysis of construction of intrinsically safe device. Their values are determined for the most unfavorable state of work or damage to the device. The values of these parameters are limited to the levels that are safe for the given explosive mixture. They should not be treated as technical parameters of the device's operation.

The conditions for compliance of the intrinsic safety parameters of connected devices are presented in the table below.

Conformity conditions for intrinsic safety parameters				
Connected external device		Condition	Gas meter	
Output voltage	U_o	≤	U_i	Input voltage
Output current	I_o	≤	I_i	Input current
Output power	P_o	≤	P_i	Input power
Maximum external capacity	C_o	$C_o \geq C_i + C_k$	C_i	Internal capacity
Maximum external inductance	L_o	$L_o \geq L_i + L_k$	L_i	Internal inductance

The distributed parameters of cables (C_k), (L_k) should be taken as:

- The least favorable parameters given by the cable manufacturer or
- Parameters measured in accordance to **EN 60079-14** or 200pF/m & 1μH/m or 30μH/Ω where the connection consists of 2 or 3 wires (with or without shield)

Rated operating parameters of used transmitters:

LFK transmitters – reed contact and LFW with output type „open collector”

CLFK-03 / CLFK-04 / CLFW-01 / CLFW-02 / CLFW-04

Closed contact resistance $R_z = 100\Omega \div 2\text{ k}\Omega$,

Open contact resistance $R_o > 100\text{ M}\Omega$,

Maximum switching frequency $f_p = 2 \text{ Hz}$.

Inductive slot transmitters and inductive proximity transmitters in NAMUR standard.

Si5-K09-Y1

Bi1-EG05-Y1

CHFI-01, CHFI-03

Maximum switching frequency $f_p = 2 \text{ Hz}$, $f_p = 0,5 \text{ kHz}$.

Rated operating voltage $U_n = 8,2\text{V}$

Rated current of the non-activated sensor $I \geq 2,1\text{mA}$

Rated current of the energized sensor $I \leq 1,2\text{mA}$

Other rated operating parameters of the transmitters are in accordance with the requirements of PN-EN 60947-5-6: 2002.

When connecting transmitters to inputs of pulse receiving devices, the polarity of conductors should be maintained. Only LFK and AFK transmitters do not require polarization.

The HF outputs are particularly useful for recording fluctuations and rapid changes of the gas flow.

Pressure measurement outputs.

Pressure measurement outputs are located on both sides of the main body of the meter (Fig. 3). They are machined as $\frac{1}{4}$ NPT taper threads (Fig. 7).

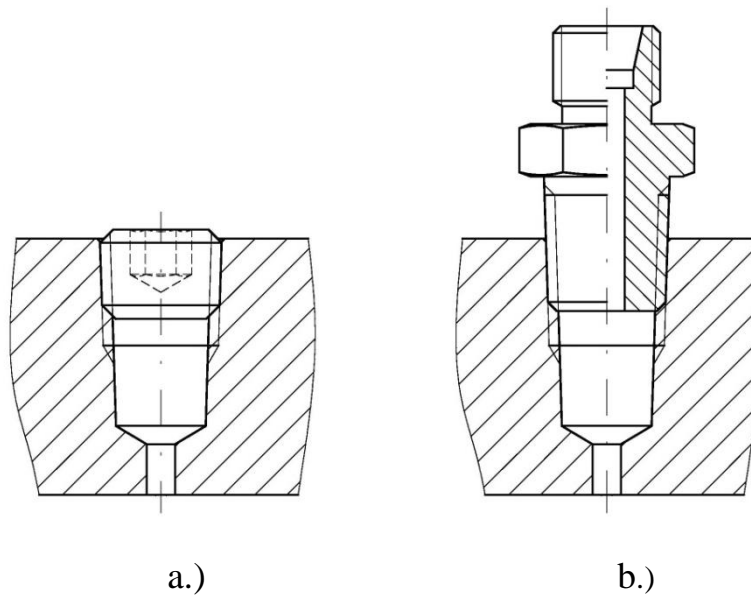

Fig. 7. $\frac{1}{4}$ NPT pressure measurement output

The outputs are adjusted to connecting pressure transducers, either directly to the socket or through impulse lines and three-way valves (impulse line connector, Fig. 7b). Outputs that are not in use are closed with plugs (Fig. 7a). Both plugs and sockets may be secured with installation seals.

Temperature measurement outputs.

CGT-02 turbine gas meters are equipped with temperature measurement outputs only when delivered as a special order version; temperature sockets are not available in standard versions.

Temperature measurement outputs are located on both sides of the main body of the meter (Fig. 3.; in case of DN50 meters versions with one or two sockets are available). Thus one or two thermowells can be installed. Standard thermowells, with M12x1.5 female thread sockets (different threads on order), are to be filled with silicone oil and fitted with one of two types of electric thermometers (Fig. 8a and 8b) or plugged (Fig. 8c). Temperature sockets, when thermowells are not installed, must be plugged with ¼ NPT plugs (like on Fig. 7a).

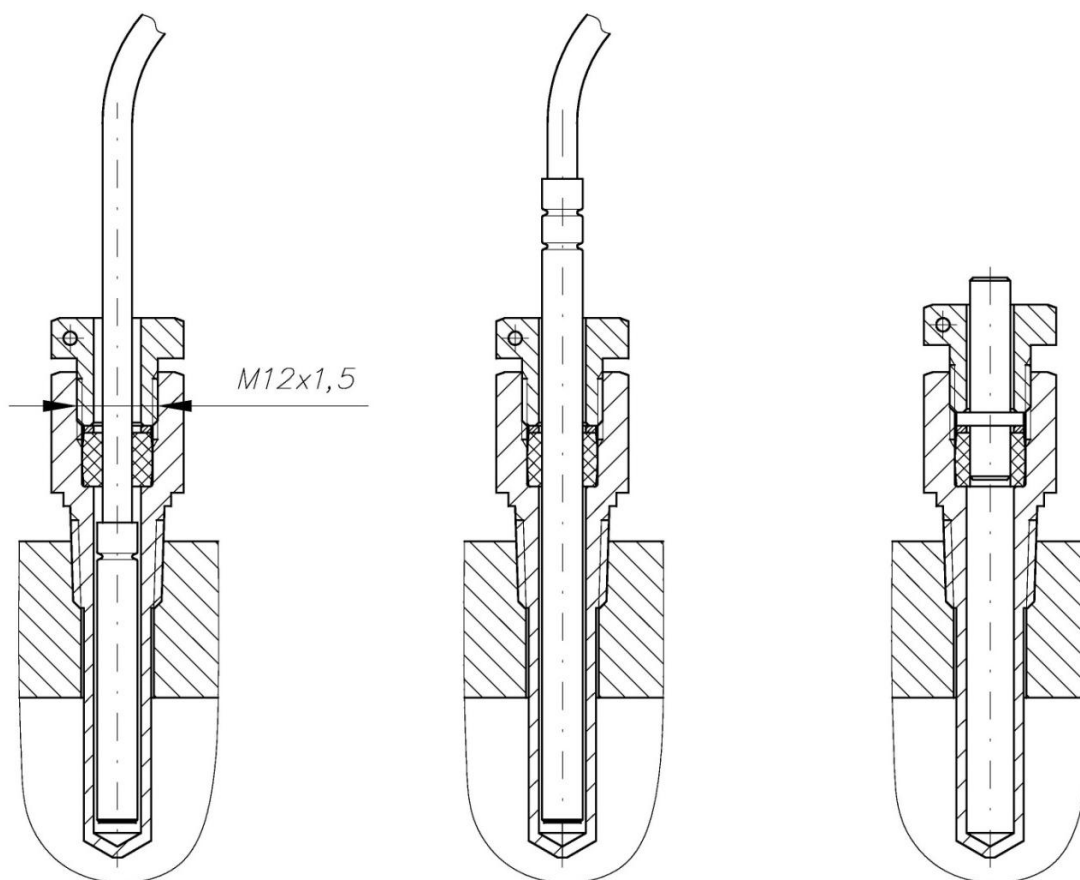

a) thermometer type 1

b) thermometer type 2

c) thermowell plugged

Fig. 8 Temperature outputs with thermowells

IV. LABELING AND SEALING

Information on the basic technical parameters of the gas meter along with the serial number and manufacture year is listed on type plates (Figs. 9a and 9b) screwed to the index head. The direction of gas flow is marked on the upper side of the meter body (red arrow) and there are labels indicating electrical (HF) and mechanical outputs as well as pressure and temperature measurement outputs on the meter (Fig. 11).

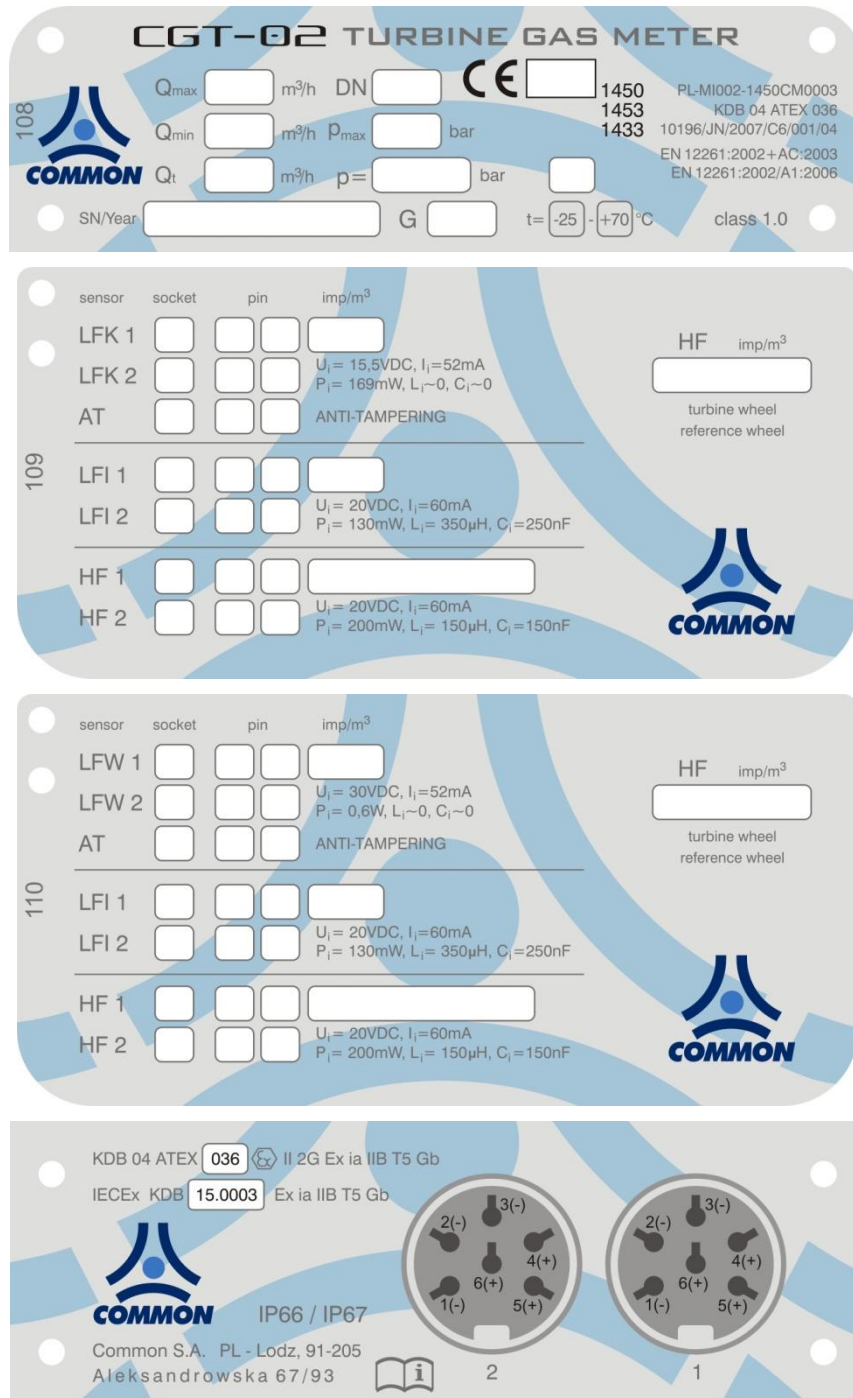

Fig. 9a. Type plates – standard version

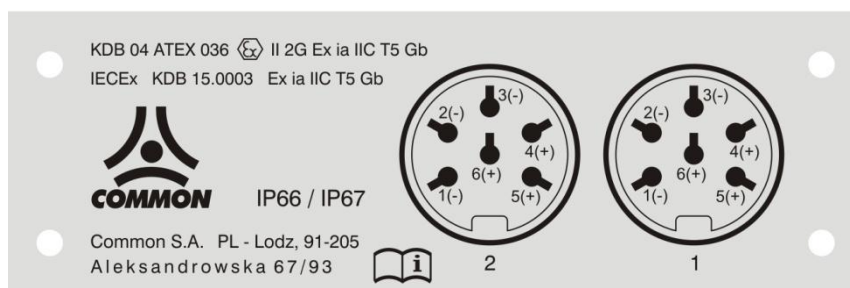

Fig. 9b. Type plates – special version example



Fig. 10. HF emitter type plate

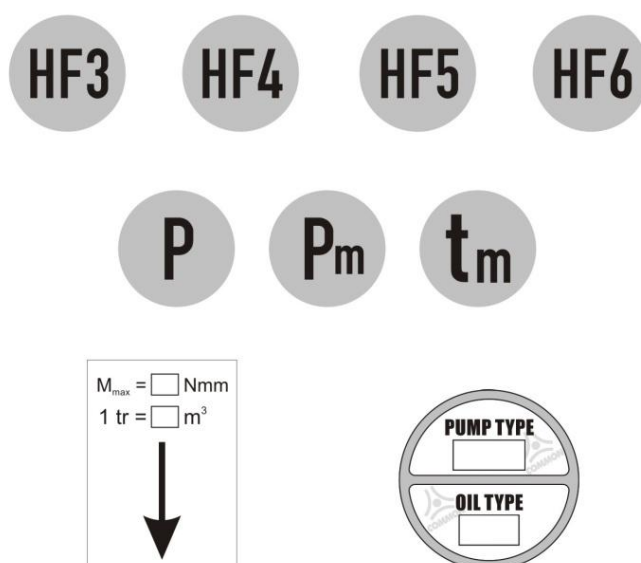

Fig. 11. Markings of pressure and temperature measurement outputs, HF outputs, mechanical output, and example of oil & oil pump type.

After verification by the authorized laboratory, each gas meter is secured with seals. Locations of the seals are shown in Fig. 12a and 12b. Seal P1 features the original validation or revalidation stamp (Fig. 13a) while seals P2, P3, P4, P5, P6, P7, P8, P9, P10 feature protection stamps (Fig. 13b).

By request of the customer, the gas meter may be delivered along with the certificate that documents its verification/calibration.

The original verification stamp seal is required for the gas meter to be considered a legal measurement device.

Installation seals placed at the connectors of the pressure transducers (P7), HF emitters (P8), temperature transducers (P9) and possibly at the mechanical output (P10), may feature stamps placed by the manufacturer, gas supplier or authorized installer. In addition, installation seals should be placed on the blinders (plugs) of unused electrical outputs and possibly on the three-way valve connected to the volume converter (see section VIII.)

The original verification period depends on metrological regulations in the country of installation. Before the expiration of the verification period, the gas meter should be submitted for secondary verification in an authorized laboratory (viable turnaround time for the verification procedure in a laboratory should be taken into account).

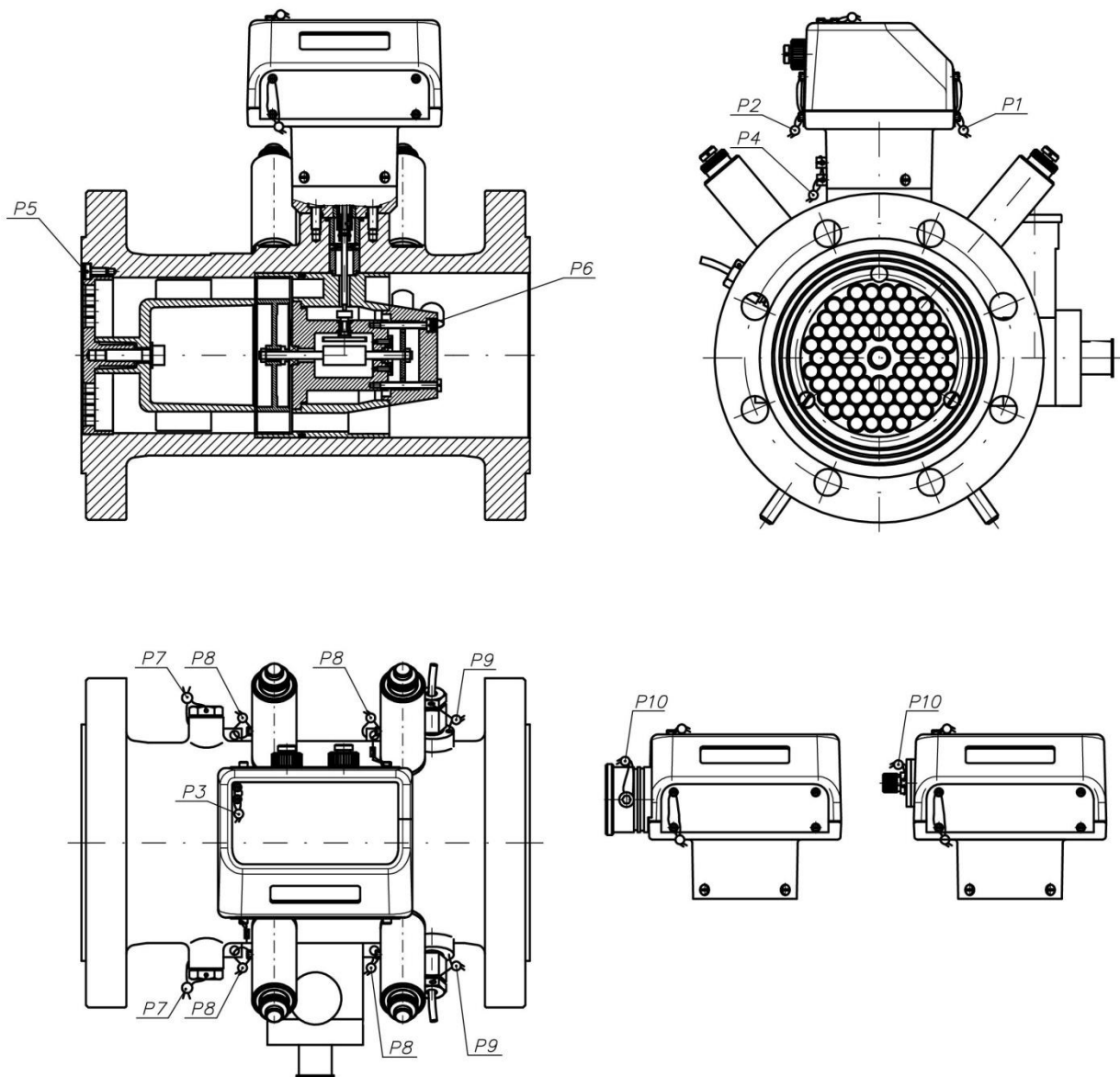

Fig. 12a. Locations of seals on CGT-02 gas meter (version 1)

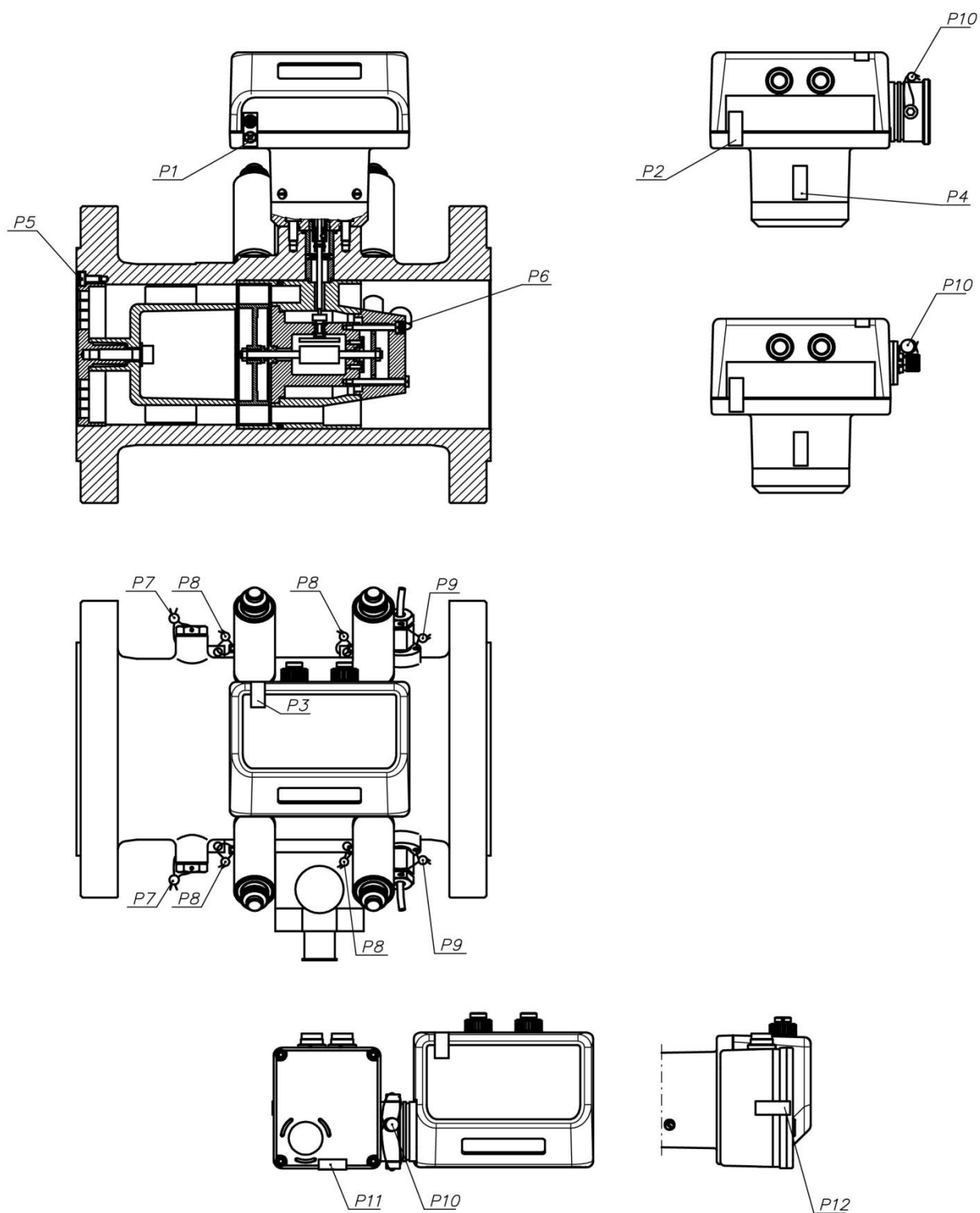

Fig. 12b. Locations of seals on CGT-02 gas meter (version 2)

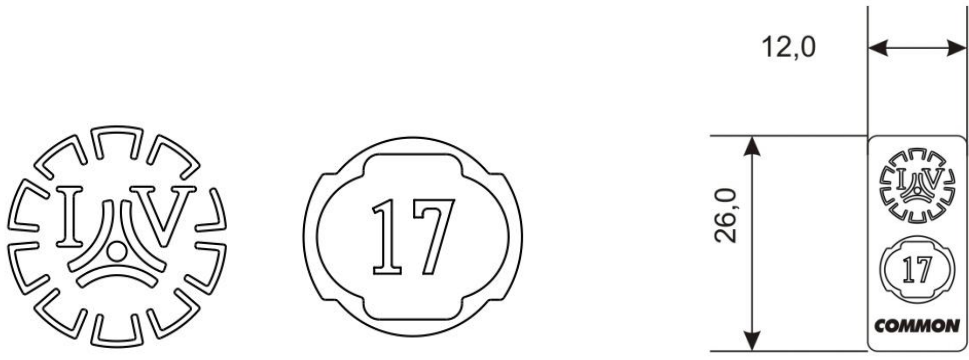

Fig. 13a. Original verification stamp

sticker seal

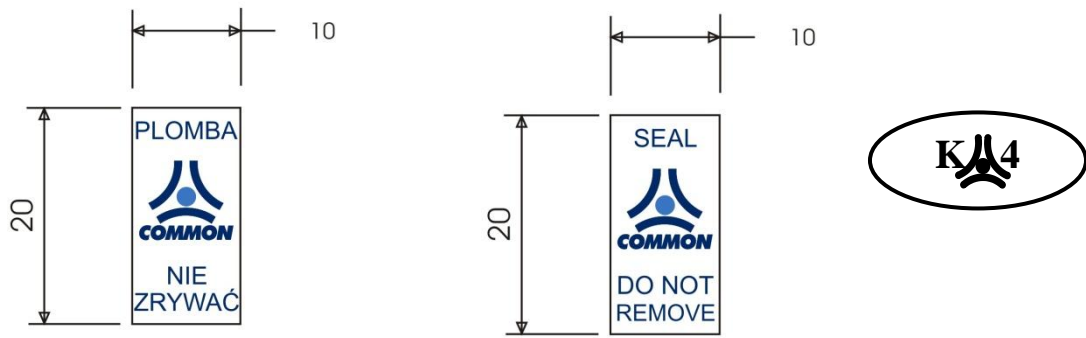

Fig. 13b. Security seals (examples)

V. PACKAGING, TRANSPORT AND STORAGE

CGT-02 gas meters are supplied in factory-made packaging which provide appropriate protection during transport and storage. For gas meter sizes from DN50 to DN100, the packaging consists of reinforced cardboard box and profiled cardboard inserts. Side walls of the box feature handle holes for transporting the gas meter. Gas meters sized DN150 and larger are placed on appropriate wooden pallets and protected by profiled inserts and cardboard covers. Appropriate information regarding the contents and restrictions on gas meter loading/unloading and transport is printed on the packaging.

Gas meters submitted for repair or renewal of legal verification should be sent in factory-made packaging or other packaging providing at least equal protection during transport.

Each turbine gas meter by Common S.A. is supplied with the following:

- a 6-pin Tuchel C091 31H006 100 2 plug to be used for connecting a volume converter or recorder to the low frequency electric signal output (in case the converter has not been connected to the gas meter in the factory);
- a 4-pin Tuchel C091 31D004 100 2 socket, if the gas meter is equipped with a HF emitter installed in the main body;
- a bottle of oil for the gas meter lubrication system (0.25 L);
- the technical manual.

**The turbine gas meter is a high precision measurement device
and should be handled with appropriate caution.**

Following principles should be observed during transport and storage of the gas meters:

1. Gas meters should not be thrown, turned over or subjected to strong impacts (e.g. during fast transport using carts without springs).
2. Due to the possibility of oil leaks, the gas meters should be transported only in the target operation position, i.e. with the oil container cap pointing upward. Position changes required by the installation process should last as short as possible (maximum a dozen or so seconds). The above does not apply to gas meters of size DN50 (unless equipped with lubrication system with piston pump).
3. One must not lift the gas meter by holding the index head. Transport of heavy gas meters should be performed with the use of lifting eye bolts located in the gas meter flanges.
4. Special care should be taken when loading, unloading and handling high pressure gas meters, as they are characterized by large weights.
5. Factory-placed covers or other shields on gas meter orifices should not be removed until directly before installation.
6. The storage site should protect the gas meter from atmospheric precipitation and moisture.
7. Care should be taken of the seals placed on the gas meter. **Damage of seals may render warranty void and legal consequences as regards the clearance of accounts between the gas supplier and the customer.**
8. It is not necessary to lubricate the bearings of gas meters when stored in the warehouse.

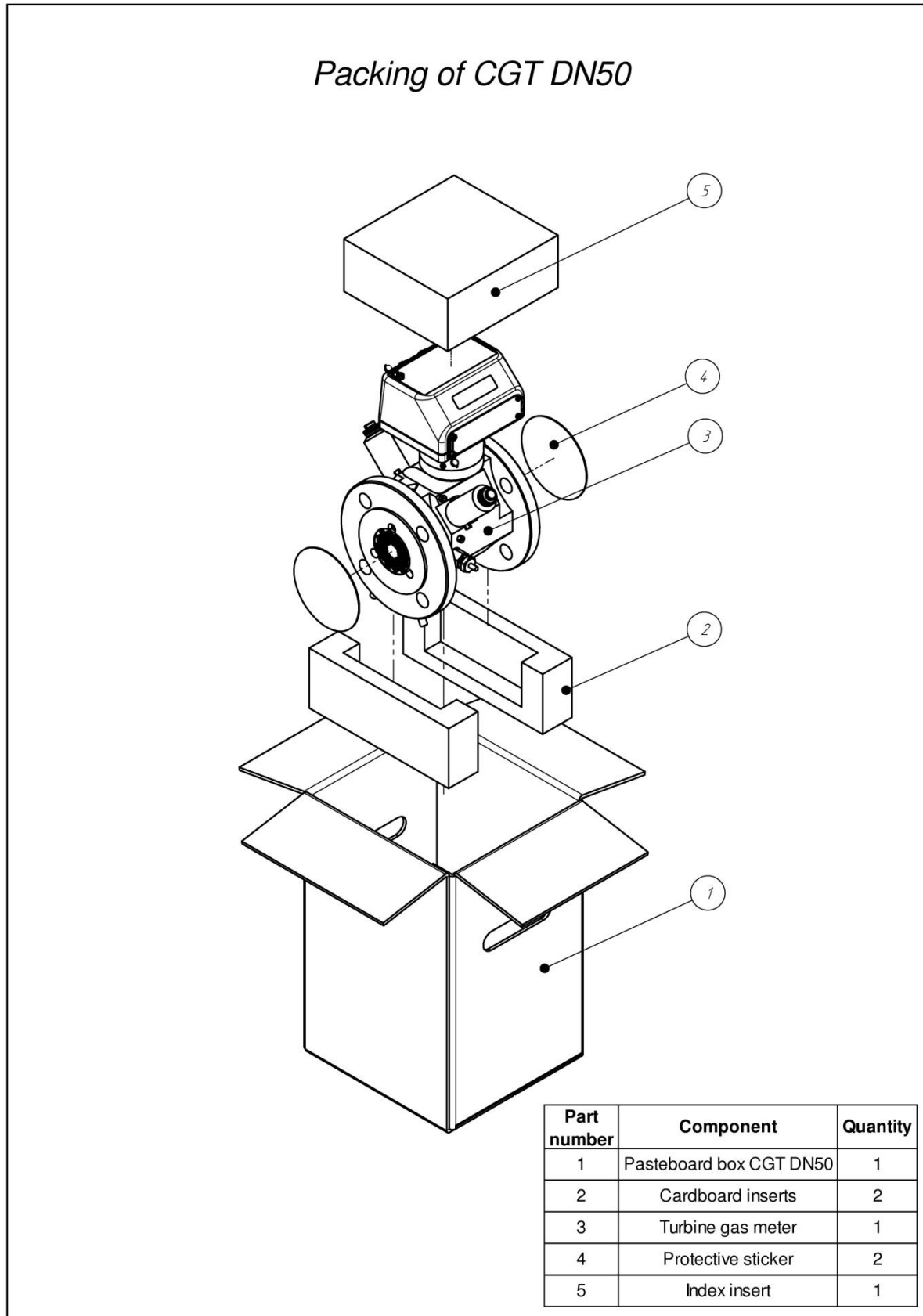
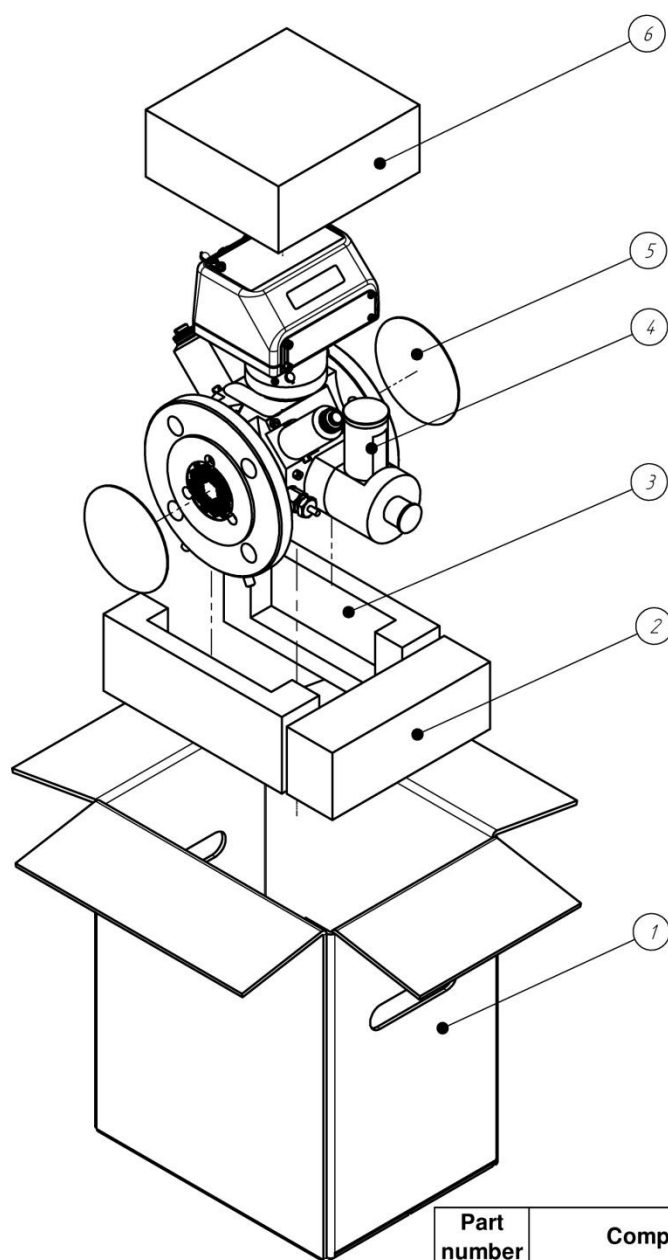

Fig. 14. Packaging of the DN50 turbine gas meter

Packing of CGT DN50 with pump



Part number	Component	Quantity
1	Pasteboard box CGT DN50	1
2	Locking insert	1
3	Cardboard inserts	2
4	Turbine gas meter	1
5	Protective sticker	2
6	Index insert	1

Fig. 15. Packaging of the DN50 turbine gas meter equipped with oil pump

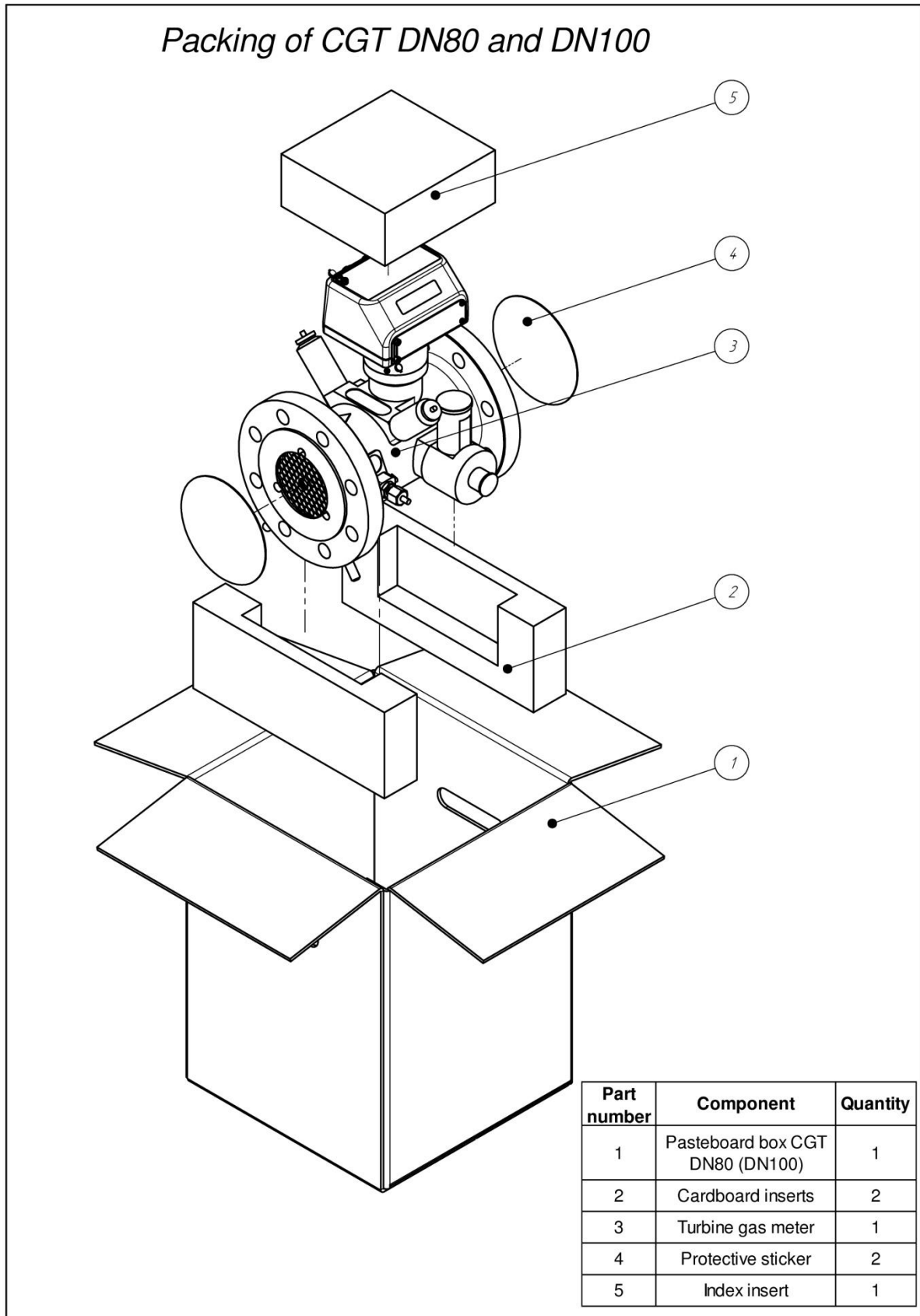

Fig. 16. Packaging of DN80 and DN100 turbine gas meters

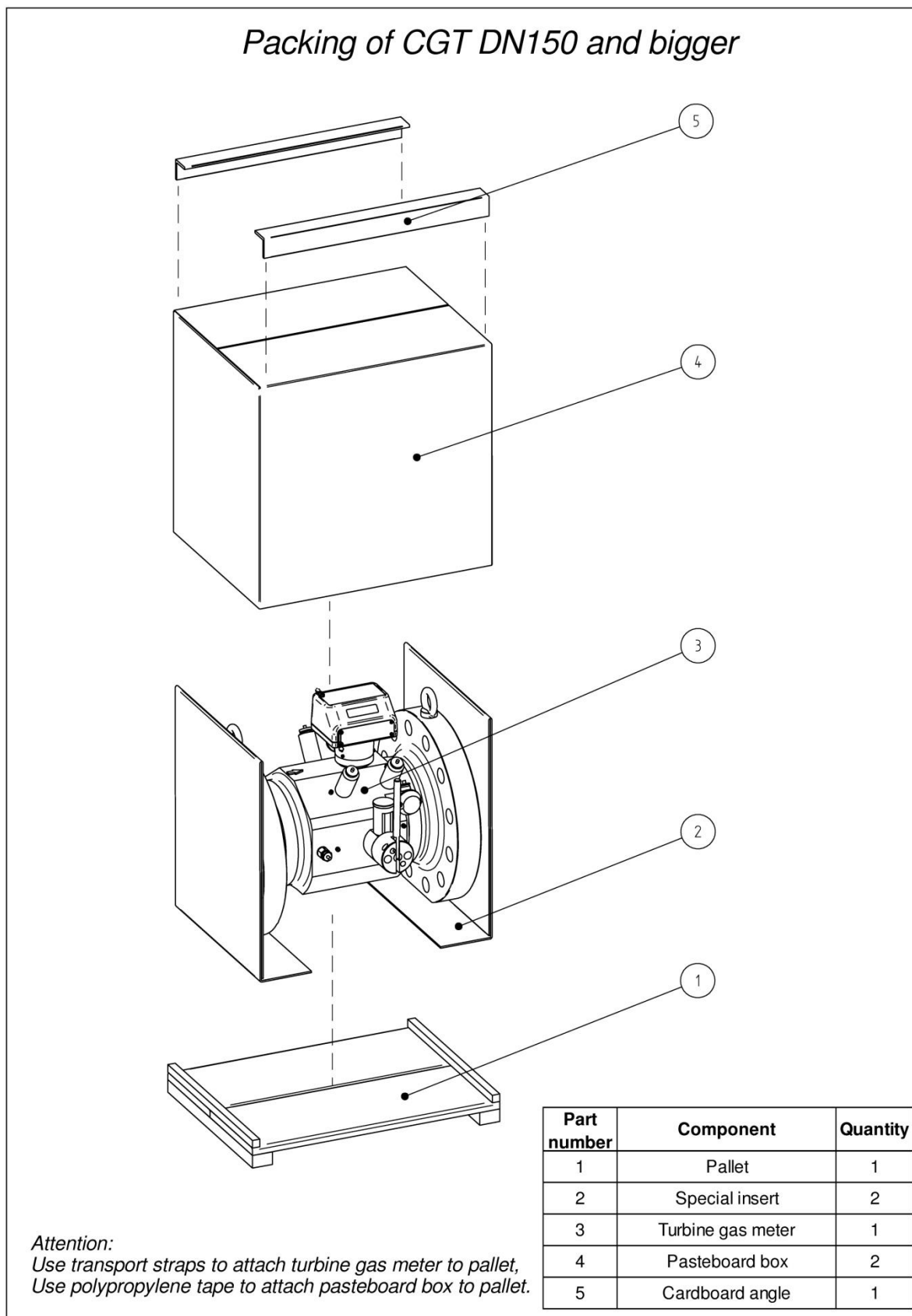

Fig. 17. Packaging of DN150÷DN400 turbine gas meters

VI. INSTALLATION AND OPERATION

Before installing the gas meter ensure that it is suitable for the system's operational parameters. In particular, the following type plate information should be taken into consideration:

- Acceptable gas meter gauge pressure [MPa], labelled p_{\max} ,
- Maximum actual flow [m^3/h], labelled Q_{\max} ,
- Acceptable working position as indicated on the type plate:
 - H horizontal (standard version),
 - VD vertical; downward vertical flow (option – by request),
 - VU vertical; upward vertical flow (option – by request),

**Maximum load of the gas meter may be exceeded
by not more than 25% for not longer than 30 minutes.**

CGT-02 gas meters can be used both indoors in stabilized temperature conditions and outdoors (open locations). In the latter case, it is recommended that the gas meter is shielded from direct exposure to atmospheric factors (metal containers, casings, roofs, shields etc.)

The gas meter must be installed between sections of pipework of appropriate nominal diameter, with axial alignment of the gas meter relative to the pipes according to gas industry regulations. The static load of the system of pipes should not exceed values given in the EN 12261:2002 standard. Table 6 lists the maximum torsion and bending moment values. Gas meters with weights of more than 50 kg should rest on supports so that their weight don't deliver additional stress onto the pipework. Gas meters should not be installed at the lowest points of the system lines, as condensate and impurities may accumulate in such areas.

Dimensions listed in Tables 3a and 3b and illustrated in Figure 18 may be helpful when designing the location for the installation of the gas meter.

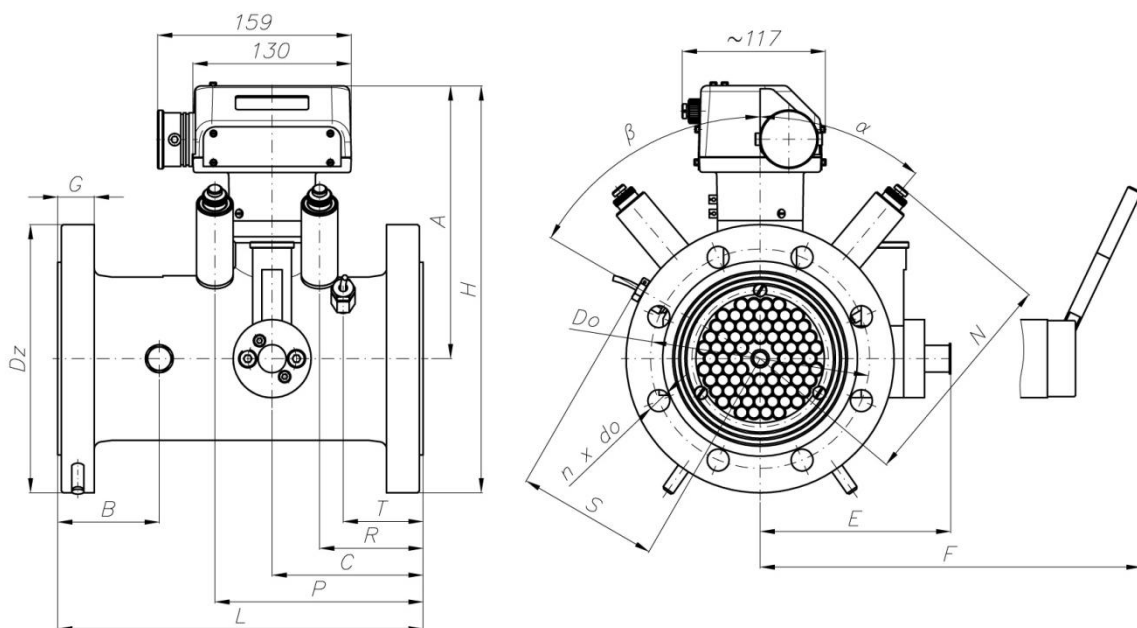

Fig. 18. Basic dimensions of CGT-02 turbine gas meters

Table 3a part I. Basic dimensions and weights of CGT-02 turbine gas meters

DN	connection (flange)	body	L	H	A	B	C	E	F	G	N	P	R	S	T	α	β	mass							
mm			mm	mm	mm	mm	mm	mm	mm	mm	mm	mm	mm	mm	mm	°	°	kg							
50	PN10/PN16	cast iron	150	281	198	42	58	150	-	20	157	91	-	85	39	45	90	11							
	PN20/ANSI150			273						20								11							
	PN25			281						20								11							
	PN10/PN16	steel		281				150	-	20								157	91	-	85	39	45	90	12
	PN20/ANSI150			273						20															11
	PN25/PN40			281						22															12
	PN50/ANSI300			281				23	12																
	PN63			288				-	216	26															15
	PN100			296						28															17
	PN110/ANSI600			281						33															13
80	PN10/PN16	cast iron	240	301	201	60	95	146	-	27	169	137	-	103	66.5	45	45								19
	PN20/ANSI150			296						27															18
	PN25									27															19
	PN10/PN16	steel		301		146		-	21	169								137	-	103	66.5	45	45	24	
	PN20/ANSI150			296					25															24	
	PN25/PN40			301					25															25	
	PN50/ANSI300			306		29		27																	
	PN63			309		-		212	28															28	
	PN100			316					31															32	
	PN110/ANSI600			306					38															30	
100	PN10/PN16	cast iron	300	325	215	101	124	157	-		30	182	171	85	116	85	40							65	24
	PN20/ANSI150			330							30														25
	PN25			330							30														25
	PN10/PN16	steel		325				157	-	23	182							171	85	116	85	40	65		32
	PN20/ANSI150			330						25															34
	PN25/PN40			333						25															36
	PN50/ANSI300			343				32	42																
	PN63			340				-	223	30															39
	PN100			348						35															46
	PN110/ANSI600			353						45															52
150	PN10/PN16	cast iron	450	375	242	125	180	185	-	32		208	231	141	142	141	35							60	47
	PN20/ANSI150			415						32															46
	PN25			392						32															47
	PN10/PN16	steel		375		185		-	25	208	231							141	142	141	35	60	64		
	PN20/ANSI150			415					26														64		
	PN25/PN40			392					29														70		
	PN50/ANSI300			432		36		80																	
	PN63			415		-		251	35														86		
	PN100			420					43														96		
	PN110/ANSI600			420					54														105		

Table 3a part II. Basic dimensions and weights of CGT-02 turbine gas meters

DN mm	connection (flange)	body	L mm	H mm	A mm	B mm	C mm	E mm	F mm	G mm	N mm	P mm	R mm	S mm	T mm	α °	β °	mass kg
200	PN10/PN16	cast iron	600	435	265	212	240	-	317	30	223	333	168	157	168	30	55	70
	PN20/ANSI150			30						70								
	PN25			30						71								
	PN10/PN16	30		70														
	PN20/ANSI150	30		71														
	PN25	30		80														
	PN40	34		90														
	PN50/ANSI300	49		100														
	PN63	49		115														
	PN100	54		130														
PN110/ANSI600	388	62	140															
250	PN10	steel	750	491	293	270	330	-	343	27	244	425	258	178	225	30	55	130
	PN16			31						130								
	PN20/ANSI150			31						130								
	PN25			32						140								
	PN40			38						150								
	PN50/ANSI300			54						175								
	PN63			54						190								
	PN100			61					230									
	PN110/ANSI600			414					70	250								
300	PN10	steel	900	541	318	300	350	-	369	36	268	448	278	202	245	30	55	190
	PN16			37						190								
	PN20/ANSI150			37						200								
	PN25			38						220								
	PN40			42						240								
	PN50/ANSI300			59						260								
	PN63			59						270								
	PN100			67					330									
	PN110/ANSI600			440					74	340								
400	PN10	steel	1200	637	354	500	400	-	434	29	306	570	348	240	348	90	30	350
	PN16			32						350								
	PN20/ANSI150			37						390								
	PN25			40						420								
	PN40			50						450								
	PN50/ANSI300			58						480								
	PN63			60						490								
	PN100			80					610									
	PN110/ANSI600			504					84	580								

**Table 3a, III. Basic dimensions and weights of CGT-02 (DN50 ÷ DN150)
with casted steel bodies.**

DN mm	przyłącze (kołnierz)	L mm	H mm	A mm	B mm	C mm	E mm	F mm	G mm	N mm	P mm	R mm	S mm	T mm	α °	β °	masa kg
50	PN10	150	281	198	42	58	150	-	30	157	91	-	90	39	45	90	15
	PN16		281						30								15
	PN20/ANSI150		274						30								14
	PN25		281				-	216	30								15
	PN40		281						30								15
	PN50/ANSI300		281						30								15
	PN63		288				35	18									
	PN100		296				35	20									
	PN110/ANSI600		281				35	15									
80	PN10	240	301	201	80	95	146	-	20	170	137	-	108	66	45	45	21
	PN16		301						20								21
	PN20/ANSI150		296						24								22
	PN25		301				-	212	24								22
	PN40		301						24								22
	PN50/ANSI300		306						29								25
	PN63		309				29	25									
	PN100		316				35	31									
	PN110/ANSI600		306				39	28									
100	PN10	300	325	215	101	124	157	-	22	183	171	85	122	85	40	65	31
	PN16		325						22								31
	PN20/ANSI150		329						24								33
	PN25		333				-	223	26								34
	PN40		333						26								34
	PN50/ANSI300		342						32								40
	PN63		340				34	40									
	PN100		348				40	45									
	PN110/ANSI600		353				46	50									
150	PN10	450	385	242	155	180	185	-	22	208	231	141	147	141	35	60	60
	PN16		385						22								60
	PN20/ANSI150		382						26								60
	PN25		392				-	251	29								65
	PN40		392						29								65
	PN50/ANSI300		401						37								75
	PN63 wersja Mo		415				-	251	40								85
	PN63 wersja Mn		415						37								81
	PN100		420						45								91
	PN110/ANSI600		420				56	100									

Table 3b. Dimensions of the connections of CGT-02 turbine meters (DN50÷DN400).

DN	connection	DZ	D0	d0	n
mm	(flange)	mm	mm	mm	qty
50	PN10/16	165	125	18	4
	PN20/ANSI150	150	120.5	18	4
	PN25/40	165	125	18	4
	PN50/ANSI300	165	127	18	8
	PN63	180	135	22	4
	PN100	195	145	26	4
	PN110/ANSI600	165	127	18	8
80	PN10/16	200	160	18	8
	PN20/ANSI150	190	152.5	18	4
	PN25/40	200	160	18	8
	PN50/ANSI300	210	168.5	22	8
	PN63	215	170	22	8
	PN100	230	180	26	8
	PN110/ANSI600	210	168.5	22	8
100	PN10/16	220	180	18	8
	PN20/ANSI150	230	190.5	18	4
	PN25/40	235	190	22	8
	PN50/ANSI300	255	200	22	8
	PN63	250	200	26	8
	PN100	265	210	30	8
	PN110/ANSI600	275	216	26	8
150	PN10/16	285	240	22	8
	PN20/ANSI150	280	241.5	22	8
	PN25/40	300	250	26	8
	PN50/ANSI300	320	270	22	12
	PN63	345	280	33	8
	PN100	355	290	33	12
	PN110/ANSI600	355	292	29.5	12
200	PN10	340	295	22	8
	PN16	340	295	22	12
	PN20/ANSI150	345	298.5	22	8
	PN25	360	310	26	12
	PN40	375	320	30	12
	PN50/ANSI300	380	330	26	12
	PN63	415	345	36	12
	PN100	430	360	36	12
	PN110/ANSI600	420	349	32.5	12

DN	connection	DZ	D0	d0	n
mm	(flange)	mm	mm	mm	qty
250	PN10	395	350	22	12
	PN16	405	355	26	12
	PN20/ANSI150	405	362	26	12
	PN25	425	370	30	12
	PN40	450	385	33	12
	PN50/ANSI300	445	387.5	29.5	16
	PN63	470	400	36	12
	PN100	505	430	39	12
	PN110/ANSI600	510	432	35.5	16
300	PN10	445	400	22	12
	PN16	460	410	26	12
	PN20/ANSI150	485	432	26	12
	PN25	485	430	30	16
	PN40	515	450	33	16
	PN50/ANSI300	520	451	32.5	16
	PN63	530	460	36	16
	PN100	585	500	42	16
	PN110/ANSI600	560	489	35.5	20
400	PN10	565	515	26	16
	PN16	580	525	29.5	16
	PN20/ANSI150	600	540	29.5	16
	PN25	620	550	36	16
	PN40	660	582	39	16
	PN50/ANSI300	650	571.5	35.5	20
	PN63	670	585	42	16
	PN100	715	620	48	16
	PN110/ANSI600	685	603	42	20

Impurities inside a pipeline system carried by gas may cause mechanical damage to the gas meter or at least reduce its measurement accuracy. Therefore, a filter with efficacy not worse than 10 μm should be installed upstream the gas meter (particularly when the flowing gas contains high amounts of impurities). In addition, the inflow side of the system should be thoroughly cleaned before installing the gas meter. Conical sack filter may be placed on the inlet of the inflow section; the filter should be removed after 1 ÷ 2 months of operation. If the filter is not removed, monitoring of the filter impurity level should be provided by means of pressure drop measurements or regular check-ups. If clogged, the sack filter may be destroyed by the gas pressure, and filter debris may seriously damage the gas meter.

The manufacturer is not responsible for any damages or stoppage of the gas meter resulting from insufficient filtration of the gas flowing through the meter.

The user should be aware of certain risks associated with changes in the gas flow intensity. If the gas flow was relatively low for a long time after system initiation, the assembly-related contaminants (e.g. welding residues) are retained inside the pipework. Only after the flow is significantly increased, the contaminants may be swept away by the gas, causing gas meter damage. For this reason, the sack filter may prove useful in the period of time when maximum system capacity is being reached. In all cases, protection of the gas meter from mechanical damage is in the user's best interest.

Before completion of the installation of the gas meter ensure it is properly oriented, i.e. that the arrow on the meter body points in the direction of the gas flow.

The gas meter should be connected to pipework flanges by means of bolts meeting the requirements of the EN 1515-1, EN 1515-2, EN ISO 898-1, and ISO 898-1 standards. To make the selection of bolts easier, table 4 lists the minimum required yield strength values for materials of bolts used for flange connections for CGT-02 gas meters.

Table 4. Minimum yield strength for bolt materials R_e [MPa].

	PN10	PN16	PN20	PN25	PN40	PN50	PN63	PN100	PN110
DN50	200	200	170	220	350	190	375	410	420
DN80	150	150	270	170	275	205	285	310	445
DN100	180	180	185	140	225	285	255	305	435
DN150	165	165	185	155	245	310	250	260	360
DN200	220	150	265	160	210	305	220	345	420
DN250	190	130	165	165	235	235	305	405	340
DN300	225	160	215	165	235	255	305	340	360
DN400	175	155	170	170	255	225	240	400	350

Appropriate flange gaskets should also be selected for specific flange types and nominal pressures. Flange connections should be sealed with gaskets made of asbestos-free gasket sheet. Flat gaskets can be used for standard flanges with type “B” facings and $p_{\max} = 2$ MPa (according to EN 1514-1:1997 or EN 12560-1:2001), while meters for $p_{\max} > 2$ MPa require corrugated gaskets (according to EN 1514-4:1997 or EN 12560-4:2001).

Appropriate bolt lengths should be selected with consideration to dimensions listed in Tables 3a and 3b and the thickness of gaskets being used.

Tables 5a and 5b list the required tightening bolt torque values for flange connections.

Table 5a. Required tightening bolt torque values for flange connections – smooth, lubricated threads; M_{nom} [Nm].

	PN10	PN16	PN20	PN25	PN40	PN50	PN63	PN100	PN110
DN50	44	44	38	44	68	37	144	270	82
DN80	33	33	60	33	53	78	108	203	171
DN100	40	40	41	53	86	115	169	291	288
DN150	70	70	75	101	161	118	323	336	344
DN200	95	63	101	104	199	201	390	609	548
DN250	81	97	109	157	309	225	536	920	603
DN300	97	117	143	155	309	331	540	993	634
DN400	129	151	163	294	583	397	1000	1797	1028

Table 5b. Required tightening bolt torque values for flange connections – smooth, non-lubricated threads; M_{nom} [Nm].

	PN10	PN16	PN20	PN25	PN40	PN50	PN63	PN100	PN110
DN50	82	82	71	82	127	69	267	501	153
DN80	61	61	112	62	99	144	201	377	317
DN100	74	74	76	99	159	208	312	544	534
DN150	131	131	139	187	299	219	601	626	643
DN200	177	118	187	193	372	373	730	1141	1021
DN250	150	180	201	293	575	421	1005	1718	1129
DN300	180	217	265	290	576	617	1011	1863	1187
DN400	239	282	305	551	1089	743	1877	3379	1929

Table 6. Maximum torsional and bending moments exerted by the pipe system on the gas meter; M_{max} [Nm].

DN50	DN80	DN100	DN150	DN200	DN250	DN300	DN400
440	760	1220	2710	4470	7050	7050	7050

Before the first start up of the gas meter installed on the pipework, the oil container should be filled with oil and the turbine mechanism should be lubricated according to the guidelines listed in section VII. Only the oil supplied with the gas meter should be used for this purpose. Following oils may be used with gases listed in Table 1:

- Lubrina L12 gas meter oil – distributed by Common S.A.;
- Lubrina L23 gas meter oil – distributed by Common S.A.;
- VR09 (VELOL 9Q) machinery oil – distributed by Common S.A.;
- Shell Tellus T15 hydraulic oil.

In a typical configuration of the gas meter installation, i.e. in a bypass system (Fig. 9), the gas meter start up procedure should proceed as follows:

1. The installation of the gas meter must be conducted with valves 1, 2, 5 closed and the bypass valve 4 open. The blow-off valve 3 is left open after the system has been degassed.

2. After tightening all the bolts connecting the gas meter to the pipework, the air must be bled from the system (according to appropriate regulations). Open valve 5, while valve 3 is still open.
3. When bleeding is completed, close valve 3 making sure that the pressure increase rate is not larger than 30 ± 10 kPa/s (adjustment by opening rate of valve 5).
4. When the gas meter counter stops indicating the flow (associated with pressure equilibration), close valve 5.
5. Open valve 1, then open valve 2.
6. If valve 2 is completely open, bypass valve 4 may be closed.

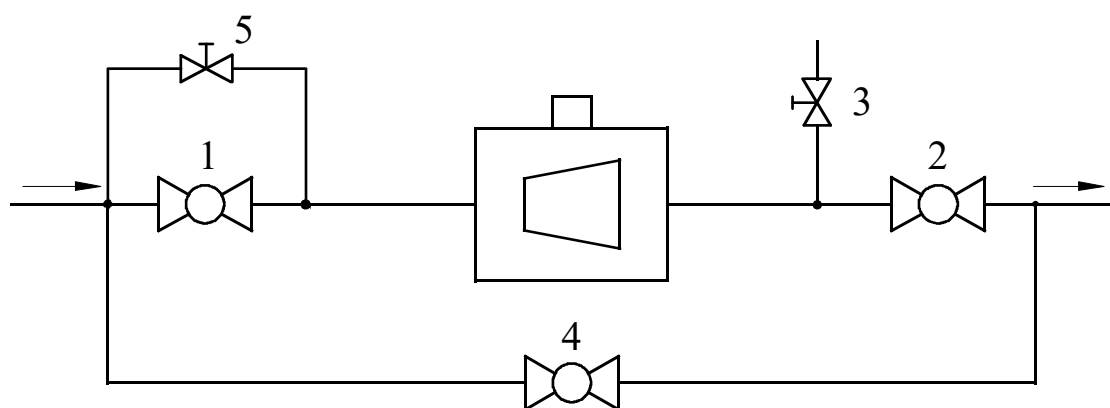

Fig. 19. A diagram of a measurement system with bypass

When removing the gas meter, the above steps should be followed in reverse order, i.e.:

1. Close bypass valve 4 first.
2. Close valve 2, then close valve 1.
3. Degas the measurement section opening the blow-off valve 3 slowly, that the pressure drop is not larger than 30 ± 10 kPa/s.

The same principles should be followed in case of any other installation types, i.e. the flow of the gas through the gas meter should be increased/decreased very slowly. Rapid change in the flow caused by sudden opening of a valve may damage the measurement turbine due to excessive difference in pressure upstream and downstream of the rotor.

If there is a risk of a gas meter overload (i.e. exceeding Q_{max} by more than 25%) during its exploitation, the use of a restrictor orifice is recommended. The orifice should be installed at a distance of 5÷10 nominal diameters (DN) downstream the gas meter. The orifice dimensions are selected individually on the basis of the nominal diameter and gas flow, pressure and temperature. Common S.A. may design and deliver appropriate orifice at customer's request.

Counter readout correctness should be checked after installing the gas meter. Every drum of the counter should turn smoothly and a full turn of a drum should turn the neighbouring left drum by 1/10 of a full turn.

Unused electrical output sockets must remain plugged with factory-made plugs and installation seals.

VII. OPERATION MONITORING, MAINTENANCE, FAILURES, REPAIRS

In any doubt regarding the correctness of gas meter readings, the gas meter should be removed from the system and submitted to an appropriate laboratory verification of its metrological characteristics. The test may be performed using the control element, without removing the legal verification seal. One of the HF emitters installed in the gas meter body may act as a control element. If no HF emitter has been installed in the gas meter, either a **CHFI-01** or a **CHFI-03** HF emitter should be connected to act as a control element. The external control element may be installed in either of the HF3 and HF4 main body sockets (Fig. 3), after the protection seal and the plug have been removed. The control element (HF emitter) should be screwed in at a depth allowing for a proper (i.e. consistent with the Namur standard) emitter signal to be obtained. After completion of the test and removal of the control element, the socket should be tightly closed using the plug. A protection seal should be placed on the plug.

CGT-02 gas meters are equipped with a turbine bearings lubrication system (does not apply to the standard version of DN50 gas meters). The only activity required as part of the maintenance is periodic lubrication of bearings. Lubrication is carried out by pumping a proper amount of oil (Table 7) from the oil container into the turbine assembly by pressing the pushbutton at the front panel of the piston pump type P1 (under the oil pump cover) or pulling the piston lever in case of pumps D1, D2 or D3. The strength required for the plunger stroke is lower than 100N. At each lubrication, the level of oil in the container should be inspected. The oil should be visible through the transparent part of the oil container.

Gas meters designed for $p_{\max} = 0.5$ MPa may be equipped with a special lubrication valve instead of the oil pump. In that case lubrication is achieved by injecting an appropriate dose of oil through the lubrication valve from a syringe included in the set. Table 7 lists the recommended oil doses.

For gases listed in Table 1, lubrication should be performed after each gas portion V [m³] as given in Table 7, but not less frequently than once a month. For refinery gases, sewage gases and sludge digestion gases, lubrication should be performed once every week.

Table 7. Recommended numbers of strokes (n) and oil volumes (V_{oil})

Pump type P1 and D1				Pump type D2 and D3			
G	V	n	V_{oil}	G	V	n	V_{oil}
	[m ³]	strokes	[cm ³]		[m ³]	strokes	[cm ³]
(G65)	65 000	3	1	G650	650 000	5	4
G100	100 000	6	2	G1000	1 000 000	5	4
G160	160 000	6	2	G1600	1 600 000	8	6.5
G250	250 000	9	3	G2500	2 500 000	8	6.5
G400	400 000	9	3	G4000	4 000 000	10	8
G650	650 000	12	4	G6500	6 500 000	10	8
G1000	1 000 000	12	4				

Information on the type of oil to be used is presented on the lid of the oil container or on the stopper of the lubrication valve.

Dust and other impurities may be removed from the gas meter surface using a cloth soaked in soap and water. Do not clean with solvents or other chemicals.

In case of any incorrectness in gas meter operation (e.g. irregular counter work or counter stoppage, elevated noise, crackling, oil leaks), the gas meter should be immediately submitted to repair.

Gas meter repairs may be performed only by the manufacturer or a company authorized by the manufacturer. Users must not attempt to repair the gas meters themselves!

Repairs involving the necessity of removing the primary validation seals require renewed legal approval of the gas meter.

CGT-02 gas meters are subject to manufacturer's warranty. The warranty proceedings are in line with the general trade law regulations.

VIII. ADDITIONAL EQUIPMENT

Lubrication kit for lubricating gas meters equipped with lubrication check valve

Gas meters CGT-02 series operating in HV positions can be adapted to external lubrication by means of syringes. These meters are equipped with a system of ducts to transport lubricating oil to the bearings and a special check valve. Application of oil should be performed by means of a lubrication kit supplied with a meter. The kit consists of a bottle with oil and a disposable syringe. It is intended to use when operating pressure does not exceed 0.5 MPa.

Lubrication procedure is shown below (Fig. 20) and involves:

- a. removing a valve cover,
- b. preparation of the lubrication kit,
- c. drawing proper amount of oil (table 7) into a syringe,
- d. inserting the tip of the syringe into a valve slot,
- e. pressing (slowly) the oil into the gas meter (lubrication system),
- f. pulling the syringe tip out from the valve slot and putting on the valve cover back.

a)



b)



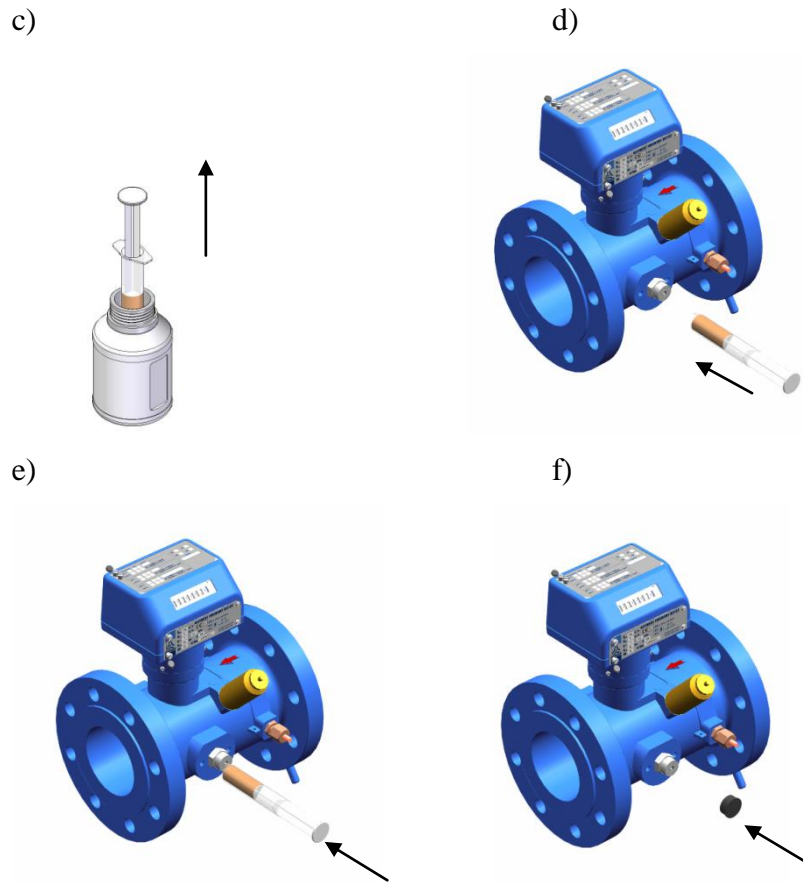

Fig. 20 Lubrication procedure of a gas meter equipped with a lubrication check valve

LF Replaceable transmitters type CLFK-04 or CLFW-04

As the special execution the CGT-02 gas meters can be equipped with index housing adapter for replaceable transmitters. CLFK-04 (reed contact) or CLFW-04 (Wiegand) transmitters (rys. 21a) can be, in case of malfunction, replaced without the necessity of disassembling the index head and removing the initial verification seals or calibration seals. The permissible power supply parameters of the transmitters are specified on the name plates (Fig. 21b).

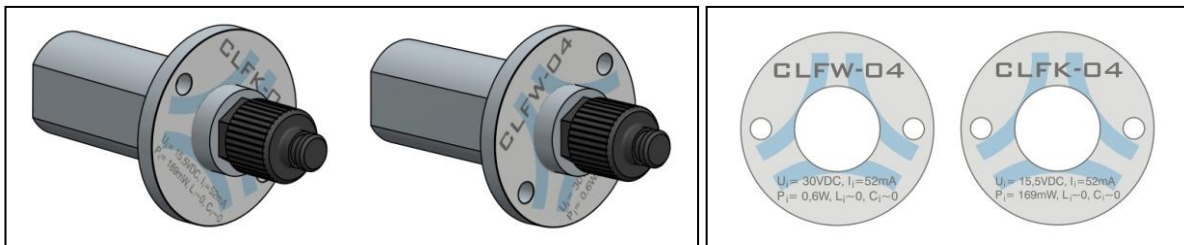

Fig. 21a Replaceable transmitters

Fig. 21b Transmitters name plates

The installation of transmitters is presented on Fig. 22 (a, b, c, d).

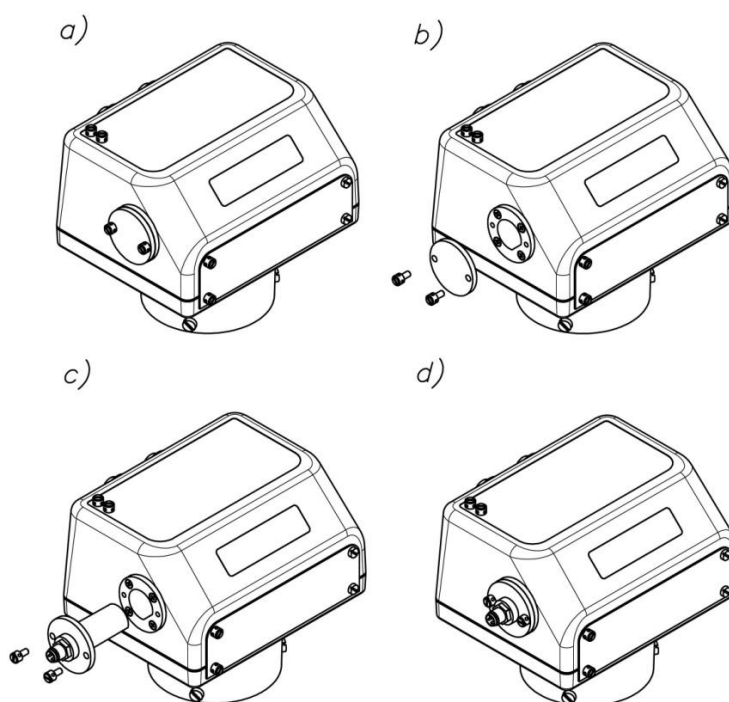

Fig. 22. The installation method of replaceable transmitters

NOTE !
CLFK-04 & CLFW-04 transmitters must not be used interchangeably.
Index head is adapted to one type of transmitter only.

CWSL Encoder (option)

CWSL Encoder can be connected to the optional mechanical output. There are 3 versions of (optional) Encoders available: CWSL-N, CWSL-A, CWSL-M (Fig. 23). Data sent from CWSL-N are equal to data on the index.



Fig. 23 CWSL Encoder adapted for connection with the index of CGT-02 gas meter.

Connecting a gas meter to a volume converter

In accordance with custody transfer requirements, it is often demanded (or recommended) that gas meters are connected to electronic devices such as data loggers or volume converters and data transmission devices. Common S.A. manufactures such devices, e.g. battery/grid-powered volume converters CMK and data loggers CRS. Common S.A. may deliver such devices on special orders, together with installation services. Exemplary installations are presented in Figs. 24 and 25.

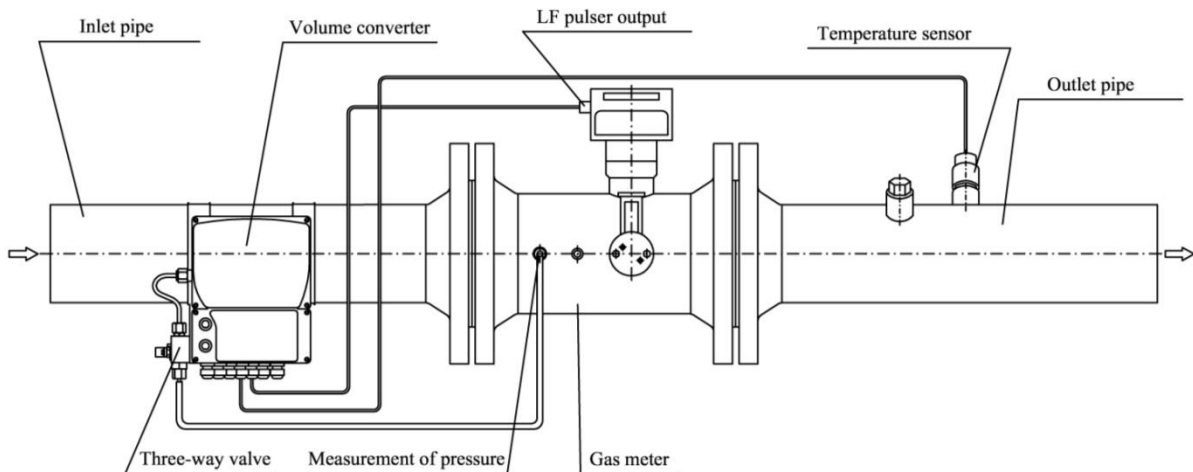

Fig. 24. A measurement set of CGT-02 gas meter and CMK-02 volume converter (the converter is installed in the inflow section)

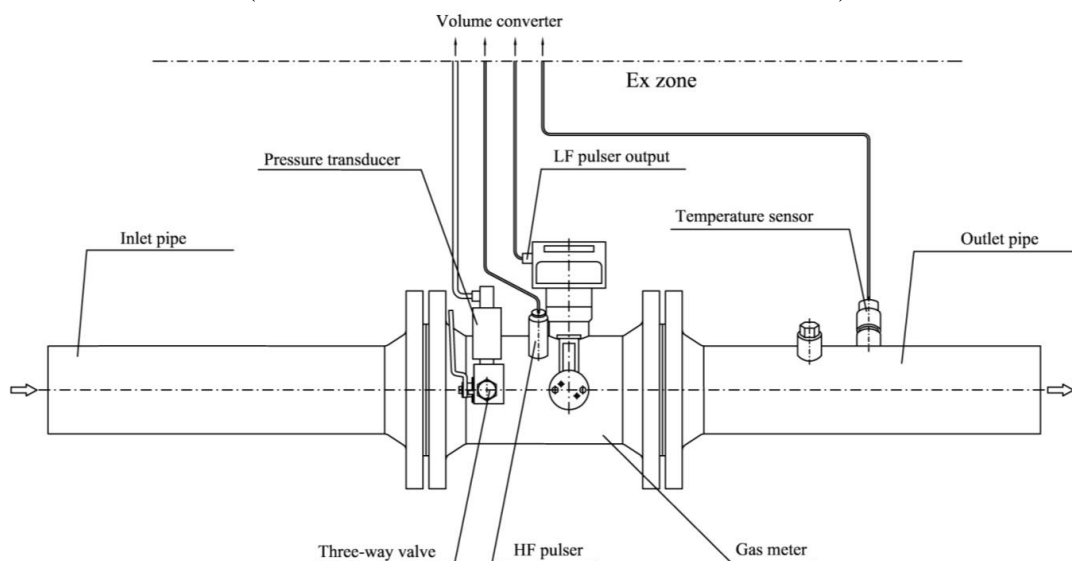

Fig. 25. Connections between a gas meter and volume converter located outside the Ex zone and powered from the 220 V power grid

The converter receives three input signals: the flow signal (from the low- or high-frequency pulse emitter), the pressure signal and the temperature signal. The pressure signal is received at the pressure measurement output. Installation of three-way CKMT valve (Fig. 26) on the pressure measurement output (or elsewhere, on a pressure measurement channel) is recommended. It enables an easy disconnection, removal, inspection and replacement of pressure transducer, if required.



Fig. 26. CKMT three-way valve

The valve handle position is secured by a seal. The valve may be operated only under supervision of the gas company representative; after operation, the handle is again secured with an installation seal.

The temperature measurement signal is received from the emitter installed in appropriate temperature socket in the outflow section of pipework (downstream the gas meter) (Figs. 24 and 25) or in a temperature socket in the gas meter.

One should keep in mind that all activities associated with connection of any additional equipment to the gas meter are also associated with removing the protection seals and thus may be performed only by representatives of the gas company or the manufacturer. Unused electrical output sockets must remain plugged with factory-made plugs and installation seals.

IX. LIST OF STANDARDS AND TECHNICAL SPECIFICATIONS

- EN 12261:2002+AC:2003
Gas meters – Turbine gas meters
- EN 12261:2002/A1:2006
Gas meters – Turbine gas meters
- EN 13463-1:2009 (PN-EN 13463-1:2010)
Non-electrical Equipment For use in Potentially Explosive Atmospheres - Part 1:
Basic Method And Requirements
- EN 60079-0:2012 + A11:2013 (PN-EN 60079-0:2013-03 + A11:2014-03)
Explosive atmospheres – Part 0: Equipment – General Requirements
- IEC 60079-0:2011 (ed.6)
Explosive atmospheres – Part 0: Equipment – General Requirements
- EN 60079-11:2012 (PN-EN 60079-11:2012)
Explosive atmospheres – Part 11: Equipment Protection By Intrinsic Safety 'i'
- IEC 60079-11:2011 (ed.6)
Explosive atmospheres – Part 11: Equipment Protection By Intrinsic Safety 'i'
- EN 60529:1991 + A1:2000
Degrees of protection provided by enclosures (IP Code)
- EN 60947-5-2:2007
Low-voltage switchgear and controlgear – Part 5-2: Control circuit devices
and switching elements – proximity switches.
- EN 60947-5-6:2000
Low-voltage switchgear and controlgear – Part 5-6: Control circuit devices
and switching elements – DC interface for proximity sensors and switching amplifiers
(NAMUR)
- WUDT/UC/2003
Requirements of office of Technical Inspection – Pressure Equipment

	<p>After expiration of the life cycle period, the gas meter should under no circumstances be discarded into municipal waste containers. The Waste Act of 27 April 2001 imposes an obligation for selective collection of metallic waste. Gas meters should be best returned to the manufacturer who would recycle them in an appropriate practice. If unable to do so, the user is obliged to deliver the gas meter to an appropriate recycling point.</p> <p>Gas meter packaging should never be discarded into municipal waste containers. The packaging has been appropriately labelled; pursuant to the Act of 11 May 2001 on packaging and packaging waste, the user is obliged to submit the packaging for an appropriate recycling process.</p>
---	--

Notice:

Technical specification and construction of CGT-02 gas meters may change due to improvements made within the limits of certifications. This publication serves as general information only and all specifications are subject to confirmation by COMMON S.A.